

PRIMARY CALIBRATORS

MODEL 4046/4146

USER'S GUIDE

P/N 1980512, REVISION F
MARCH 2016



START SEEING THE BENEFITS OF REGISTERING TODAY!

Thank you for your TSI instrument purchase. Occasionally, TSI releases information on software updates, product enhancements and new products. By registering your instrument, TSI will be able to send this important information to you.

<http://register.tsi.com>

As part of the registration process, you will be asked for your comments on TSI products and services. TSI's customer feedback program gives customers like you a way to tell us how we are doing.



UNDERSTANDING, ACCELERATED

TSI Incorporated - Visit our website **www.tsi.com** for more information.

USA	Tel: +1 800 874 2811	India	Tel: +91 80 67877200
UK	Tel: +44 149 4 459200	China	Tel: +86 10 8219 7688
France	Tel: +33 1 41 19 21 99	Singapore	Tel: +65 6595 6388
Germany	Tel: +49 241 523030		

©2015 TSI Incorporated

Printed in U.S.A.

Copyright©

TSI Incorporated / 2004-2016 / All rights reserved.

Address

TSI Incorporated, 500 Cardigan Road, Shoreview, MN 55126 USA

	WARNING
	TSI calibrators employ a heated platinum sensor. They should not be used in the presence of flammable or explosive gases or mixtures.

	Caution
	TSI calibrators are not medical devices under FDA 510k and in no situation should they be utilized for human respiration measurements.

LIMITATION OF WARRANTY AND LIABILITY (effective February 2015)

(For country-specific terms and conditions outside of the USA, please visit www.tsi.com.)

Seller warrants the goods, excluding software, sold hereunder, under normal use and service as described in the operator's manual, to be free from defects in workmanship and material for **24 months**, or if less, the length of time specified in the operator's manual, from the date of shipment to the customer. This warranty period is inclusive of any statutory warranty. This limited warranty is subject to the following exclusions and exceptions:

- a. Hot-wire or hot-film sensors used with research anemometers, and certain other components when indicated in specifications, are warranted for 90 days from the date of shipment;
- b. Pumps are warranted for hours of operation as set forth in product or operator's manuals;
- c. Parts repaired or replaced as a result of repair services are warranted to be free from defects in workmanship and material, under normal use, for 90 days from the date of shipment;
- d. Seller does not provide any warranty on finished goods manufactured by others or on any fuses, batteries or other consumable materials. Only the original manufacturer's warranty applies;
- e. This warranty does not cover calibration requirements, and seller warrants only that the instrument or product is properly calibrated at the time of its manufacture. Instruments returned for calibration are not covered by this warranty;
- f. This warranty is **VOID** if the instrument is opened by anyone other than a factory authorized service center with the one exception where requirements set forth in the manual allow an operator to replace consumables or perform recommended cleaning;
- g. This warranty is **VOID** if the product has been misused, neglected, subjected to accidental or intentional damage, or is not properly installed, maintained, or cleaned according to the requirements of the manual. Unless specifically authorized in a separate writing by Seller, Seller makes no warranty with respect to, and shall have no liability in connection with, goods which are incorporated into other products or equipment, or which are modified by any person other than Seller.

The foregoing is **IN LIEU OF** all other warranties and is subject to the **LIMITATIONS** stated herein. **NO OTHER EXPRESS OR IMPLIED WARRANTY OF FITNESS FOR PARTICULAR PURPOSE OR MERCHANTABILITY IS MADE. WITH RESPECT TO SELLER'S BREACH OF THE IMPLIED WARRANTY AGAINST INFRINGEMENT, SAID WARRANTY IS LIMITED TO CLAIMS OF DIRECT INFRINGEMENT AND EXCLUDES CLAIMS OF CONTRIBUTORY OR INDUCED INFRINGEMENTS. BUYER'S**

EXCLUSIVE REMEDY SHALL BE THE RETURN OF THE PURCHASE PRICE DISCOUNTED FOR REASONABLE WEAR AND TEAR OR AT SELLER'S OPTION REPLACEMENT OF THE GOODS WITH NON-INFRINGEMENT GOODS.

TO THE EXTENT PERMITTED BY LAW, THE EXCLUSIVE REMEDY OF THE USER OR BUYER, AND THE LIMIT OF SELLER'S LIABILITY FOR ANY AND ALL LOSSES, INJURIES, OR DAMAGES CONCERNING THE GOODS (INCLUDING CLAIMS BASED ON CONTRACT, NEGLIGENCE, TORT, STRICT LIABILITY OR OTHERWISE) SHALL BE THE RETURN OF GOODS TO SELLER AND THE REFUND OF THE PURCHASE PRICE, OR, AT THE OPTION OF SELLER, THE REPAIR OR REPLACEMENT OF THE GOODS. IN THE CASE OF SOFTWARE, SELLER WILL REPAIR OR REPLACE DEFECTIVE SOFTWARE OR IF UNABLE TO DO SO, WILL REFUND THE PURCHASE PRICE OF THE SOFTWARE. IN NO EVENT SHALL SELLER BE LIABLE FOR LOST PROFITS, BUSINESS INTERRUPTION, OR ANY SPECIAL, INDIRECT, CONSEQUENTIAL OR INCIDENTAL DAMAGES. SELLER SHALL NOT BE RESPONSIBLE FOR INSTALLATION, DISMANTLING OR REINSTALLATION COSTS OR CHARGES. No Action, regardless of form, may be brought against Seller more than 12 months after a cause of action has accrued. The goods returned under warranty to Seller's factory shall be at Buyer's risk of loss, and will be returned, if at all, at Seller's risk of loss.

Buyer and all users are deemed to have accepted this LIMITATION OF WARRANTY AND LIABILITY, which contains the complete and exclusive limited warranty of Seller. This LIMITATION OF WARRANTY AND LIABILITY may not be amended, modified or its terms waived, except by writing signed by an Officer of Seller.

Service Policy

Knowing that inoperative or defective instruments are as detrimental to TSI as they are to our customers, our service policy is designed to give prompt attention to any problems. If any malfunction is discovered, please contact your nearest sales office or representative, or call TSI's Customer Service department at (800) 874-2811 (USA) or (001 651) 490-2811 (International) or visit www.tsi.com.

Trademarks

TSI and TSI logo are registered trademarks of TSI Incorporated.

CONTENTS

CHAPTERS

1	Unpacking and Parts Identification	1
2	Setting-Up	3
	Assembly Instructions for the Calibrators	3
	Supplying Power	4
	Connecting Filter and Flow Tubes	4
3	Operation	7
	Overview	7
	ON/OFF Switch	7
	Flow Rate Measurement	7
	Setting Flow Rates and Calibrating Instruments	7
	Dampening Module	8
4	Maintenance	11
	Flow Sensor	11
	Re-certification	11
	Cases	11
	Storage	11
5	Troubleshooting	13

APPENDIXES

A	Specifications	15
B	Primary vs. Secondary Standard	17

(This page intentionally left blank)

Chapter 1

Unpacking and Parts Identification

Carefully unpack the instrument and accessories from the shipping container. Check the individual parts against the list of components in Table 1. If any parts are missing or damaged, notify TSI immediately.

Table 1. List of Components (see figures 1-1 and 1-2)

Qty	Item Description	Part/ Model
1	Calibrator	4046 <i>or</i> 4146
1	Filter Model 4046: 22 mm 1S0 taper Model 4146: 63 mm HEPA filter with 0.375 inch barbed fittings	1602292 1602342
1	Tubing Kit Model 4046 with connectors and battery pack mounting lugs Model 4146 with connectors and battery pack mounting lugs	TK4000 TK4100
1	Battery Pack	4199
1	Soft Carrying Case Model 4046 Model 4146	1319403 1319404
1	Model 4046/4146 User's Guide	1980512
1	Dampening Module (Model 4146 only)	1040229

Table 2. Optional Accessories

Qty	Item Description	Part/ Model
1	AC Adapter 115 V, North America, ungrounded 100–240 V, NEMA 5-15 plug, grounded 100–240 V, Europlug, CEE 7/16, grounded 100–240 V, Great Britain, grounded, fused 100–240 V, Australia/NZ	2613033 8918-NA 8918-EC 8918-GB 8918-AT



Figure 1-1 Model 4046 Components

- | | |
|-----------------------------|---------------------------------|
| 1. Calibrator | 5. 6 AA-size Batteries |
| 2. Soft-Sided Carrying Case | 6. Adapter |
| 3. Mounting Lugs | 7. User's Guide |
| 4. Tubing | 8. High-Efficiency Inlet Filter |



Figure 1-2 Model 4146 Components

- | | |
|-----------------------------|---------------------------------|
| 1. Calibrator | 6. High-Efficiency Inlet Filter |
| 2. Soft-Sided Carrying Case | 7. User's Guide |
| 3. Mounting Lugs | 8. Adapters |
| 4. Latex Tubing | 9. Dampening Module |
| 5. 6 AA-size Batteries | |

Chapter 2

Setting-Up

Assembly Instructions for the Calibrators

The calibrator can be quickly attached to the battery pack by screwing the mounting lugs into the threaded holes in the base of the calibrator. The lugs should then be placed over the receiving holes in the top of the battery pack and snapped gently into place. Insert the connector from the battery pack to the receptacle in the back of the calibrator. The calibrator is now ready to use.

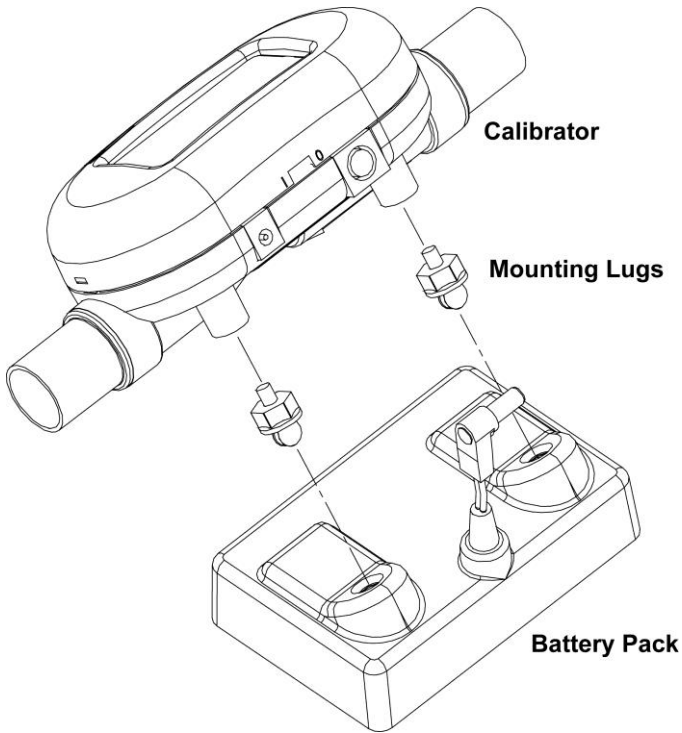

Figure 2-1 Calibrator Assembly

Supplying Power

The calibrator can be powered in one of two ways: through the power jack using the supplied 4199 battery pack or using an optional AC adapter. The DC power input connector is shown below along with the power requirements.

Power Supply: 7.5 VDC \pm 1.5 V, 300 mA maximum



Connecting Filter and Flow Tubes

The Model 4046/4146 has a thermal sensor exposed to the air flow that must be protected from foreign matter and particles. TSI supplies a filter that should be connected to the inlet of the calibrator; however, any filter will work as long as it has a minimum efficiency of 99.9%.

	Caution
	Always use a filter on the inlet of the calibrator. Failure to filter the air flow may change the calibration and/or permanently damage the sensor.

Note: Flow direction is identified by the large arrow printed on the bottom side of the calibrator and on the bottom of the battery pack.

Attach the filter to the inlet of the calibrator using supplied tubing and/or adapters. Connecting a tube to the outlet of the calibrator will create back pressure. See Appendix A for calibrator accuracy specifications when operating at various pressures. In general, minimize back pressure on the calibrator by using shorter lengths of tubing to maintain highest level of accuracy.

① Sampling Pump with internal dampening chamber

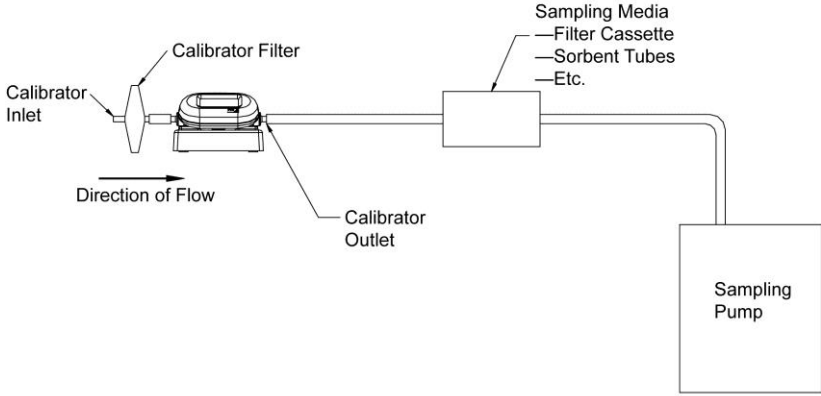

② Active Sampling Instrument with internal dampening chamber

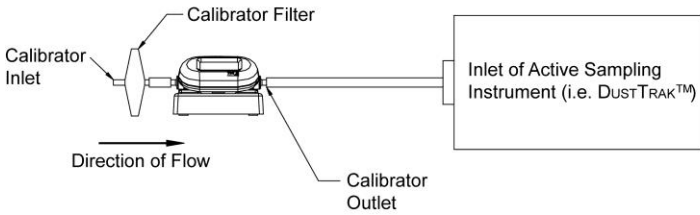

Figure 2-2 Typical Setup Configurations



Figure 2-3 Typical Dampening Module Set Up

Use the 6 in. (15 cm) tubing to connect the dampening chamber in line between the Model 4146 Calibrator and the instrument. For best results, position Dampening Module with openings to the side, off the work surface.

Chapter 3

Operation

Overview

The Model 4046/4146 Calibrator measures volumetric flow rate inside the flow tube. All measurements made by the Models 4046/4146 are NIST traceable.

ON/OFF Switch

Slide the switch to the ON position. The LCD displays volumetric flow in units of liters per minute (L/min).

Flow Rate Measurement

Flow rate data will be displayed on the Model 4046/4146 through the LCD.

Volumetric flow is displayed in units of liters per minute (L/min).

Setting Flow Rates and Calibrating Instruments

The Model 4046/4146 Calibrator may be used to set flow rates and calibrate sampling pumps or other instruments which draw an active flow sample. Be sure to follow all instrument manufacturer's flow setting and calibration procedures.

1. Start up the Model 4046/4146 Calibrator and let it warm up for 1 minute prior to setting any flow rates or conducting any calibrations.
2. Configure your sampling with the desired sampling media and sampling train to be used.
3. Connect the outlet of the Model 4046/4146 Calibrator to the inlet of the sample media (used with sampling pumps) or to the inlet of the active sampling instrument using the tubing supplied.
4. Follow the instrument manufacturer's flow setting and/or calibration procedures. The volumetric flow in units of liters per minute (L/min) will be continuously displayed on the LCD of the calibrator.

Dampening Module

The Dampening Module is included for use with systems that do *not* have internal dampening chambers. The Dampening Module (P/N 1040229) can be added in line between the end of the sampling train and the Model 4146 calibrator. The Dampening Module reduces flow pulsation with insignificant affect on flow rate or back pressure.

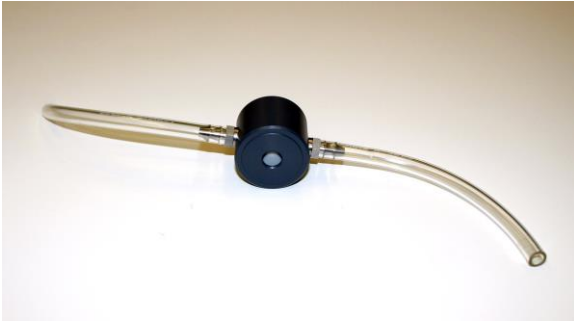

Figure 3-1 Dampening Module with Tubing Attached

All diaphragm pumps produce flow pulsations during operation. Most commercially available 3 L/min and 5 L/min sampling pumps are designed with internal dampening chambers to minimize flow pulsations.

Some common air sampling instruments that may not have internal flow pulsation dampening chambers are listed below. Contact your instrument manufacturer if you have questions. This list is just an example and is not intended to be all inclusive.

- Low flow personal sampling pumps
- Confined space meters
- Photometers
- Optical Particle Counters (OPCs)
- Condensation Particle Counters (CPCs)
- Photo Ionization Detectors (PIDs)
- Flame Ionization Detectors (FIDs)

Note: The TSI DustTrak™ and SidePak™ Sampling Pumps contain internal dampening chambers. The Dampening Module is not needed to measure flow rates with these instruments.

The TSI SidePak™ AM510 Personal Aerosol Monitor does not contain an internal dampening chamber. TSI recommends using the Dampening Module when using the Model 4146 Calibrator to measure AM510 flow rates.

(This page intentionally left blank)

Chapter 4

Maintenance

Flow Sensor

Periodically inspect the flow sensor by looking into the outlet of the calibrator. Remove dust, particles and fibers from the sensor with clean, dry compressed air. The flow sensor may break if touched.

Never run liquids through the calibrator and never touch the sensor with a brush. Dust or other deposits on the flow sensor will degrade the 4046/4146's flow accuracy.

	<p style="text-align: center;">Caution</p> <p>The calibrator must be switched off for cleaning. Only use clean, dry, compressed air when attempting to remove contamination from the sensor.</p>
---	---

Re-certification

To maintain a high degree of confidence in the measurements made by the Model 4046/4146, TSI recommends that the instrument be returned to TSI every 12 months for re-certification. The calibrator will be recalibrated and returned with a certificate of calibration to US National Institute of Standards Technology (NIST) traceable standards.

Cases

If the instrument case or storage case needs cleaning, wipe it off with a soft cloth dipped in isopropyl alcohol or mild detergent. Never submerge the calibrator or allow liquids to enter the flow tube.

Storage

When storing the calibrator, always cover the ends of flow tubes with the caps provided to prevent dust or other foreign matter from entering the tube.

(This page intentionally left blank)

Chapter 5

Troubleshooting

Table 3 lists the symptoms, possible causes, and recommended solutions for common problems encountered with Model 4046/4146 Calibrators. If the symptom is not listed, or if none of the solutions solves the problem, please contact TSI Technical Support at 1-800-874-2811 or 651-490-2811.

Table 3. Troubleshooting

Symptom	Possible Causes	Corrective Action
No display.	Unit not switched on.	Switch on the unit.
	No power to instrument.	Check power connection.
Temperature reads high at low or zero flows.	Temperature sensor is being heated from the flow sensor.	The temperature value will track the actual air temperature once the flow rate through the calibrator exceeds 1 Std L/min.
Flow readings fluctuate greatly.	The flow is fluctuating.	Improve inlet conditions or increase display averaging time.
Display shows flows over-range with no flow passing through flow tube.	The sensor may be damaged or broken.	Return calibrator to TSI for service.

Technical Contacts

- If you have any difficulty installing the Model 4046/4146, or if you have technical or application questions about this instrument, contact an applications engineer at TSI Incorporated, (651) 490-2811 or contact answers@tsi.com.
- If the Model 4046/4146 fails, or if you are returning it for service, visit our website at <http://rma.tsi.com> or contact TSI at:

TSI Incorporated

500 Cardigan Road
Shoreview, MN 55126 USA

Phone: +1-800-874-2811 (USA) or +1 (651) 490-2811

E-mail: answers@tsi.com

TSI GmbH

Neuköllner Strasse 4
52068 Aachen
GERMANY

Telephone: +49 241-52303-0

Fax: +49 241-52303-49

E-mail: tsigmbh@tsi.com

Web: www.tsiinc.de

TSI Instruments Ltd.

Stirling Road
Cressex Business Park
High Wycombe, Bucks
HP12 3ST
UNITED KINGDOM

Telephone: +44 (0) 149 4 459200

Fax: +44 (0) 149 4 459700

E-mail: tsiuk@tsi.com

Web: www.tsiinc.co.uk

Appendix A

Specifications

	Specifications*
Flow Measurement	
Measurement Range	Model 4046: 2.5 to 300 L/min Model 4146: 0.01 to 20 L/min
Accuracy Air	Model 4046: $\pm 2\%$ of reading or 0.05 std. L/min, whichever is greater Model 4146: $\pm 2\%$ of reading or 0.005 std. L/min, whichever is greater at standard conditions (21.1°C and 101.3 kPa) See notes 1 through 5 below.
Instrument Temp. Range	
Operation, Ambient Storage, Ambient	0 to 50°C -20 to 60°C
Physical Dimensions	
External Dimensions	Model 4046: 7.2 in. x 2.5 in. x 2.1 in. (18.3 cm x 6.4 cm x 5.3 cm) Model 4146: 5 in. x 2 in. x 1.25 in. (12.7 cm x 5 cm x 3.2 cm)
Tube Adapters (Inlet & Outlet)	Model 4046: 3.0 Model 4046: 22 mm male ISO taper Model 4146: 0.375 inch O.D. straight
Weight	Model 4046: 1.2 lbs (0.5 kg) Model 4146: 1.7 lbs (0.8 kg)
Flow Body Material	Polycarbonate
Warm-up Time	1 min
Power	Battery pack 7.5 VDC \pm 1.5 V, 300 mA maximum

Notes:

- Accuracy stated at standard conditions of 21.1°C and 101.3 kPa.
- Accuracy stated with air temperature and flow body temperature within $\pm 10^\circ\text{C}$ of one another.
- Accuracy stated measuring dry air (less than 10% R.H.).
- Includes $\pm 0.5\%$ of reading repeatability.
- Volumetric flow rate is calculated from the mass flow measurement. Add an additional 0.25% of reading to the flow accuracy to account for the uncertainty in measuring air temperature and pressure.

*Specifications subject to change without notice.

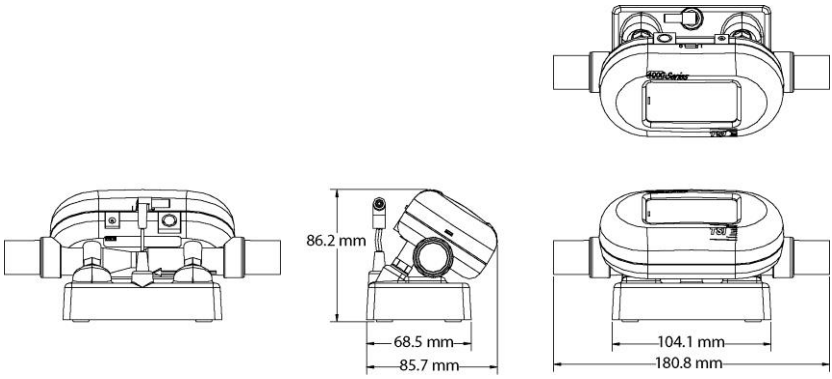

Figure A-1 Model 4046 Dimensions

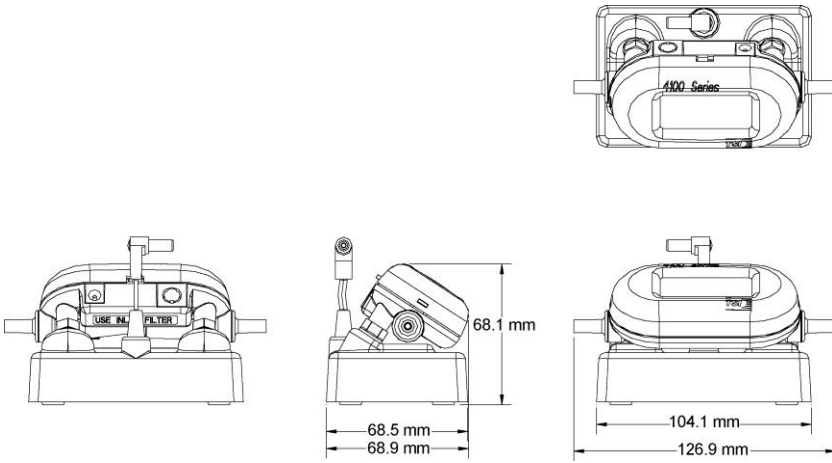

Figure A-2 Model 4146 Dimensions

Appendix B

Primary vs. Secondary Standard

By definition, a primary standard is one whose value is without relation or comparison to any other reference. There are three primary standards—mass, length, and time. There is no primary standard for air flow rate since the measurement is dependent on all three primary standards of mass, length, and time. Hence, all air flow calibrators are secondary standards in the strictest sense of the definition.

In the industrial hygiene arena, the terms “primary” and “secondary” have become generally accepted terms over time and should not be confused with actual primary and secondary standards as prescribed by the National Institute of Science and Technology (NIST). Some manufacturers of calibrators, by their own definition, refer to their products as “primary” standards referring to the manner they are applied and generally accepted for use in the industry. Other manufacturers adequately refer to their instruments as “calibrators”. There are no industry standards established for such designations based on the measurement technology being employed.

What is important is accuracy, repeatability, and regular, documented verification to a higher accepted standard such as NIST. Both primary and secondary calibrators must be verified on a regular basis and that testing recorded. Some guidelines recommend annual calibration to a higher accepted standard while others suggest as frequently as every 30 days or before a significant survey. It is important to have a certificate of traceability to NIST or other industry recognized testing organization indicating that an instrument has been calibrated against some mother device verified by NIST.

(This page intentionally left blank)



UNDERSTANDING, ACCELERATED

TSI Incorporated – Visit our website www.tsi.com for more information.

USA Tel: +1 800 874 2811

UK Tel: +44 149 4 459200

France Tel: +33 1 41 19 21 99

Germany Tel: +49 241 523030

India Tel: +91 80 67877200

China Tel: +86 10 8219 7688

Singapore Tel: +65 6595 6388

P/N 1980512 Rev. F

©2016 TSI Incorporated

Printed in U.S.A.

