

SENSAIR™

Gas Detector User Manual

Document No. 360-0228-01 Rev A



SENSIDYNE®

Sensidyne, LP • 1000 112th Circle N, Suite 100
St. Petersburg, Florida 33716 USA
800-451-9444 • +1 727-530-3602 • +1 727-539-0550 [fax]
web: www.sensidyne.com • e-mail: info@sensidyne.com

How to Use This Manual

This manual is a guide for using the SensAir Toxic Detector. It contains information on the detector, detector components, and the Normal Operation Display. It also shows how to mount and wire the detector, initial setup, zeroing, and span calibration. In addition, it covers commonly used operations regarding alarms and relays. For reference, the entire menu structure is outlined in [Appendix- Menu Map](#)

Because the SensAir Toxic Detector is menu driven, it is important to become familiar with how the magnetic switch controls are used to navigate through the menus, select specific menu items, and change the many different parameters available to the user. The Menu Map in the Appendix will help you navigate the structure.

SYMBOLS

Symbols used in this manual shall conform to CSA C22.2 61010-1-12/UL61010-1 3rd Edition Table 1 Symbols.

The manual must be consulted in all cases where  is found.

Table of Contents

How to Use This Manual	3
Packing List and Notices	6
WARNINGS	7
1 INTRODUCTION	9
2 SENS AIR PART NUMBER SYSTEM	11
3 COMPONENTS	12
3.1 Condulet Housing	12
3.2 Display	12
3.2.1 Electronics.....	14
3.3 The Sensor Assembly.....	14
4 INSTALLATION	15
4.1 Location	15
4.2 Detector Installation (Enclosure).....	15
4.3 Detector Location.....	16
4.3.1 Wiring	16
4.3.2 Detector Wiring Diagram.....	16
4.3.3 Allowable Line Length	17
4.3.4 Remote Sensor Option.....	17
4.3.5 Installation Procedure	18
5 OPERATION	20
5.1 Communication Modbus & BACnet Options.....	20
5.2 Output Current	20
5.3 Sensor Interferents	20
5.3.1 Combustible Flooding	21
5.3.2 Combustible Inhibition and Poisoning.....	21
5.3.3 Combustible Sensor K-Factor Adjustment.....	22
6 START UP PROCEDURE	23
7 CALIBRATION	24
7.1 Equipment.....	24
7.2 Zeroing (Toxic and Combustible Only)	24
7.3 Select Calibration Gas Concentration	24
7.4 Calibration Procedure	25

7.5	4 to 20 mA Adjustment	25
8	MAINTENANCE	27
8.1	Sensor replacement:	27
8.2	Sensor Assembly Replacement	27
9	APPENDIX- MENU MAP	29
10	APPENDIX- FAULT CODES.....	34
11	APPENDIX- DIMENSIONAL DRAWINGS	35
11.1	Dimensions.....	35
12	APPENDIX- CALIBRATION EQUIPMENT	37
13	APPENDIX – ACCESSORIES AND SPARES.....	39
14	APPENDIX- SPECIFICATIONS	40
15	APPENDIX- DECLARATION OF CONFORMITY	41
16	APPENDIX- ALLOWABLE LINE LENGTHS	43
17	OPTIONAL COMMUNICATION / RELAY BOARD.....	44
18	SENSAIR MODBUS REGISTER ADDRESSES (OPTION)	49
19	SENSAIR MODBUS SPECIFICATIONS (OPTION).....	50
20	SENSAIR BACNET SPECIFICATIONS (OPTION).....	51
21	WIRING RELAYS (OPTIONAL).....	68
22	APPENDIX- TROUBLESHOOTING GUIDE	69
23	APPENDIX- COMBUSTIBLE SELECTIVITY FACTORS.....	70
24	RETURNED MATERIAL AUTHORIZATION.....	73

Packing List and Notices

You should have the following items:

- SensAir Gas Detector unit
- Magnetic Screwdriver
- User Manual (this document)

Always check to make certain you have received all of the items listed above. If you have any questions or need assistance, contact your Sensidyne Representative, or call 800-451-9444 or +1 727-530-3602

PROPRIETARY NOTICE

This manual was prepared by Sensidyne, LP exclusively for the owner of the SensAir Gas Detector. The material within this manual is the proprietary information of Sensidyne, LP and is to be used only to understand and operate the instrument. By receiving this document, the recipient agrees that neither this document nor the information disclosed within nor any part shall be reproduced or transferred, physically, electronically or in any form or used or disclosed to others for manufacturing or for any other purpose except as specifically authorized in writing by Sensidyne, LP.

COPYRIGHT NOTICE

©2014, Sensidyne, LP All rights reserved. Information contained in this document is protected by copyright. No part of this document may be photocopied, reproduced, or translated to another program or system without prior written authorization from Sensidyne, LP

TRADEMARK NOTICE

Sensidyne, the Sensidyne logo, SensAlert, the SensAlert & SensAir logos, T-O-D & Test-on-Demand are registered trademarks of Sensidyne, LP. The trademarks and service marks of Sensidyne, LP are protected through use and registration in the United States of America.

SOFTWARE LICENSE

The software included with the SensAir Detector is the property of Sensidyne, LP and shall remain the property of Sensidyne, LP in perpetuity. The software is protected by U.S. and international copyright laws and is licensed for specific use with the SensAir Gas Detector. The user may not reverse-engineer, disassemble, decompile, or make any attempt to discover the source code of the software. The software may not be translated, copied, merged or modified in any way. The user may not sublicense, rent, or lease any portion of the software. The right to use the software terminates automatically if any part of this license is violated.

DISCLAIMER

SENSIDYNE, LP ASSUMES NO RESPONSIBILITY WHATSOEVER, TO ANY PARTY WHOSOEVER, FOR ANY PROPERTY DAMAGE, PERSONAL INJURY, OR DEATH CAUSED BY OR RESULTING FROM, IN WHOLE, OR IN PART, THE IMPROPER USE, INSTALLATION, OR STORAGE OF THIS PRODUCT BY THE USER, PERSON, FIRM, ENTITY, CORPORATION OR PARTY NOT ADHERING TO THE INSTRUCTIONS AND WARNINGS OR NOT ADHERING TO ALL FEDERAL, STATE, AND LOCAL ENVIRONMENTAL AND OCCUPATIONAL HEALTH AND SAFETY LAWS AND REGULATIONS. THE SELLER SHALL NOT BE LIABLE FOR DIRECT, INDIRECT, CONSEQUENTIAL, INCIDENTAL OR OTHER DAMAGES RESULTING FROM THE SALE AND USE OF ANY GOODS AND SELLER'S LIABILITY HEREUNDER SHALL BE LIMITED TO REPAIR OR REPLACEMENT OF ANY GOODS FOUND DEFECTIVE. THIS WARRANTY IS IN LIEU OF ALL OTHER WARRANTIES, EXPRESSED OR IMPLIED, INCLUDING BUT NOT LIMITED TO THE IMPLIED WARRANTIES OF MERCHANTABILITY AND FITNESS FOR USE OR FOR A PARTICULAR PURPOSE WHICH ARE EXPRESSLY DISCLAIMED.

WARNINGS**READ AND UNDERSTAND ALL WARNINGS BEFORE USE**

Read and understand ALL warnings before using this product. Failure to read, understand, and comply with ALL warnings could result in property damage, severe personal injury, or death.

Product is calibrated prior to shipment. However, this product must be calibrated prior to initial use and at regular intervals in accordance with this User Manual to ensure proper operation.

Failure to calibrate and operate this product in accordance with this User Manual may result in the malfunction of the product.

Read and understand ALL applicable federal, state, and local environmental health and safety laws and regulations, including OSHA. Ensure complete compliance with ALL applicable laws and regulations before and during use of this product.

The user/installer must understand the Hazardous Area Protection Concepts and Area Classifications applicable to their operation.

UNDER NO CIRCUMSTANCES should this product be used except by qualified, trained, technically competent personnel and not until the warnings, User Manual, labels, and other literature accompanying this product have been read and understood.

Failure to read and understand the User Manual may result in preventable severe personal injury or death.

ALWAYS wash your hands thoroughly after handling, calibrating, or servicing this product.

ALWAYS wear eye protection (such as safety goggles), face shield, chemical resistant gloves and chemical resistant clothing when handling chemicals, or calibration sources.

DO NOT get chemicals, gases, fumes, or vapors in your eyes or on your skin, as they may cause severe burns to skin and eyes. If chemicals, gases, fumes, or vapors get in your eyes or on your skin, wash the affected area with copious amounts of water and call a physician immediately.

ALWAYS avoid any contact of acids with your skin or eyes. Seek immediate medical attention for any contact with acids.

ALWAYS calibrate in a well-ventilated area. Adequate precautions should be taken to prevent the buildup of ANY calibration sources or vapors. Avoid breathing ANY calibration fumes or vapors as they may be hazardous to your health.

ALWAYS dispose of chemicals and calibration sources in compliance with ALL applicable safety laws, regulations, and guidelines for proper disposal. Failure to do so may result in environmental damage, property damage, personal injury or death.

ALWAYS close ALL containers of chemicals used with this product after use.

ALWAYS ensure that any compressed calibration substance sources are empty prior to disposal, should they be used.

ALWAYS use clean, dry, inert materials to contain and transfer substances used for calibration.

DO NOT remove, cover, or alter any label or tag on this product, its accessories, or related products.

DO NOT operate this product should it malfunction or require repair. Operation of a malfunctioning product, or a product requiring repair may result in serious personal injury or death.

DO NOT attempt to repair or modify instrument, except as specified in the Operation & Service Manual. If repair is needed, contact the Sensidyne Service Dept. to arrange for a Returned Material Authorization (RMA) [Returned Material Authorization](#)

Users should refer to SDS and suppliers' instructions for proper handling and safety instructions for any chemicals used with this equipment.

WARNINGS
READ AND UNDERSTAND ALL WARNINGS BEFORE USE

DO NOT attempt to repair or modify instrument, except as specified in the Operation & Service Manual. If repair is needed, contact the Sensidyne Service Department to arrange for a Returned Material Authorization (RMA). Use ONLY genuine SENSIDYNE® replacement parts when performing any maintenance procedures described in this manual. Failure to do so may seriously impair instrument performance and affect Certification. Repair or alteration of the product beyond the scope of these maintenance instructions, or by anyone other than an authorized SENSIDYNE® service technician, could cause the product to fail to perform as designed and persons who rely on this product for their safety could sustain severe personal injury or death.

The product is intended for non-hazardous locations and is not intended as a life safety device. It is intended to detect gas and act as a warning signal for the protection of personnel or building structures.

The SensAir Toxic Gas Detector is an ambient air monitoring device. Restricting the access of ambient air to the sensor may result in less than optimal monitoring performance.

Prolonged exposure to excessively high concentrations of gas may cause the sensor to produce erroneous readings.

Always make use of a rainshield to protect against variations caused by environmental conditions.

Perform tests only within the specified operating ranges.

Sudden changes in pressure may cause temporary fluctuations in the sensor reading.

Important Calibration Considerations:

- Unit calibration must be done at altitude.
- Verify concentration of calibration gas before making calibration adjustments.
- Concentration can be altered by:
 - Deterioration of the concentration of compressed calibration gas sources during storage.
 - Interaction of the calibration gas with materials used to contain and transfer the gas, as for example, absorption onto and permeation through certain plastics.
 - Interaction of the calibration gas with materials and/or ambient contaminants, as for example, absorption into water.

If further translation is required, please contact the Sensidyne EU Authorized Representative (see Back Cover for contact information).

1 INTRODUCTION

This manual provides specific information concerning the installation, operation, calibration, and maintenance of the SensAir Gas Detector.

IMPORTANT: Owners of the SensAir Gas Detector must read this manual in its entirety in order to ensure proper operation of the detector.

Product specifications are located in [Appendix Specifications](#).

Different versions of the detector are available [Part Number Table](#). The selection of the version best suited to an application depends upon the application requirement.

The SensAir Gas Detector is a single-point device capable of detecting the presence of various gases. The detector detects gas in either ppm, %Volume or %LEL concentrations. The standard detector consists of a display board and a power supply board, housed in a heavy-duty enclosure, a sensor specifically designed to detect Oxygen, Toxic or Combustible gases, and optionally, a relay/communication board. A complete monitoring system consists of the detector and a separate read-out device & power supply capable of monitoring a 4-20 mA output and supplying 24 Vdc power. There are versions of the detector for hazardous and non-hazardous areas.

POWER RATINGS:

Zone 1 / Div 1

24VDC, 500mA COMBUSTIBLE (ATEX and IECEx only)
 24VDC, 300mA O2/TOXIC
 Tamb -40°C to +75°C COMBUSTIBLE (ATEX and IECEx only) Tamb -20°C to +50°C O2/TOXIC
 Optional Relay PCA 30V AC/DC 5 Amps
 Termination Resistance < 500 Ohms

Zone 2 / Div 2

24VDC, 500mA COMBUSTIBLE (ATEX and IECEx only)
 24VDC, 300mA O2/TOXIC
 Tamb -40°C to +55°C COMBUSTIBLE (ATEX and IECEx only)
 Tamb -20°C to +50°C O2/TOXIC
 Optional Relay PCA 30V AC/DC 2.5 Amps
 Termination Resistance < 500 Ohms

 The unit contains a non-user replaceable Re-settable 0.75A 30V Fuse (F1).

The system is housed in a Stainless-Steel Metal enclosure, a Blue Metal enclosure, or a NEMA 4X Polymeric enclosure.

The product is intended for non-hazardous or hazardous locations and is not intended as a life safety device. It is intended to detect gas and act as a warning signal for the protection of personnel or building structures. Optional Relay contacts are user selectable as Latching or Non-latching.

It is recommended that the user refer to ISA-RP12.13, Part II-1987 or equivalent international recommended practice for guidance in the use of the instrument.

APPROVAL STANDARDS:

ATEX / IECEx / Class 1 Div-1 / Zone-1 STANDARDS:

IEC 60079-0:2011 Ed. 6	ANSI/ISA 60079-0 (12.00.01) - 2013
IEC 60079-1:2014 Ed. 7	ANSI/UL 60079-1 - 2015
IEC 60079-15 Ed. 4	C22.2 No. 0-10 (R2015)
EN 60079-0:2012/A11:2013	C22.2 No. 30-M1986 (R2016)
EN 60079-1:2014	FM 3810 – 2017
EN 60079-15:2010	FM 3600 – 2011
CAN/CSA-C22.2 No. 60079-0:15	FM 3615 – 2006
CAN/CSA-C22.2 No. 60079-1:16	

IECEx Zone 2 STANDARDS:

IEC 60079-0, Edition 7.0
IEC 60079-7, Edition 5.1
IEC 60079-15, Edition 5.0

ATEX Zone 2 STANDARDS:

EN 60079-0:2018
EN 60079-7:2015/A1:2018
IEC 60079-15:2017

North American Division 2 STANDARDS:

C22.2 No. 213-17
UL 121201 Ninth Edition

North America Zone 2 STANDARDS:

CAN/CSA-C22.2 No. 60079-0:15
CAN/CSA-C22.2 No. 60079-7:16
CAN/CSA-C22.2 No. 60079-15:16
UL 60079-0:2013, 6th Edition
UL 60079-7:2017, 5th Edition
UL 60079-15:2013, 4th Edition

2 SensAir Part Number System

SensAir Detectors

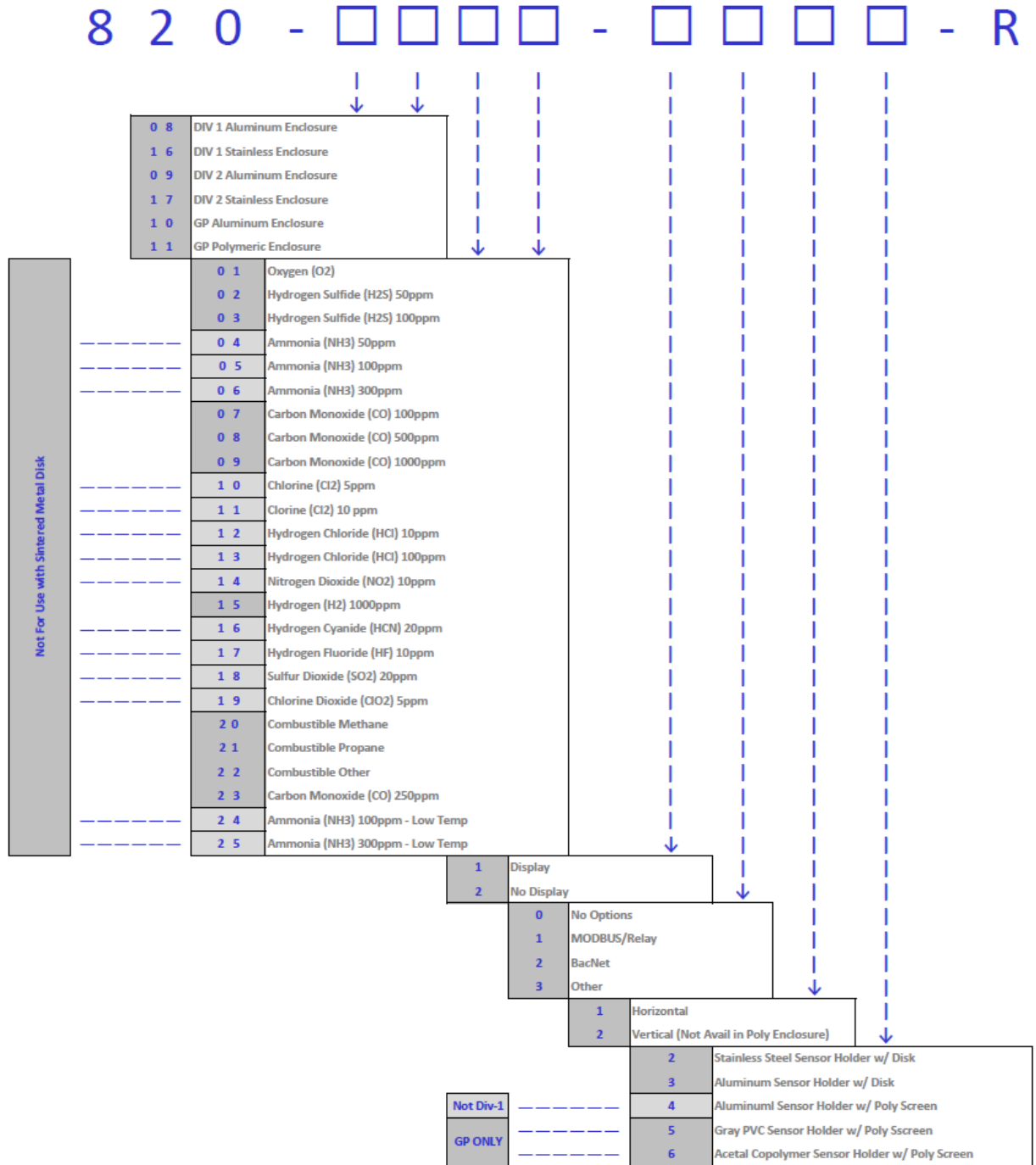

3 Components

3.1 Condulet Housing

The condulet housing is a heavy-duty weather-resistant barrier between the electronics module and the ambient environment. The housing is available with a window for the display of the detector or without the window (in the aluminum enclosure).

An o-ring on the condulet seated between the condulet cover and the base provides water-tight protection for the internal electronic components. It allows the detector to be used outdoors during inclement weather conditions.

One port is utilized for the sensor interface, one to two ports are utilized for instrument wiring, unused ports must be plugged with IECEx/ATEX, CUS Zone and DIV certified plug(s).

Only suitably certified cable entry devices or conduit shall be used for connections.

No modifications to the Flamepath should be done by the end user. For information on the flameproof joints for the condulet Instrument Housing the manufacturer shall be contacted.

3.2 Display

The detector with display has Program and Up and Down selector magnetic switches. These are controlled via the magnetic screwdriver provided with the unit. Information on operating the various controls is located in the [Appendix Menu Map](#).

The display shows the following:

(1) **Gas Concentration**

The gas concentration is displayed in large characters; units of measure are ppm or %volume.

(2) **PROGRAM Control (Switch)**

The Program switch is used to enter the programming menu. The switch is also used to select/save a menu item.

(3) **▲ and ▼**

The ▲ and ▼ control arrows are used to scroll up or down a list of items. These controls are also used to increase or decrease a value (such as an alarm setpoint).

Holding the wand near the control (switch) causes the displayed value to either increase or decrease automatically.

(4) **LEDs**

The detector display has LEDs that light up when there is an alarm or fault condition occurring.

Also, when the magnetic wand is brought close to a magnetic switch the LED associated with that switch lights up, confirming that contact has been made between the wand and the switch.

The detector without display requires the use the Hand-Held Display to program and calibrate the unit. The Hand-Held Display unit is sold separately. Part number for the Hand-Held Display is 821-0602-01-R.

Prior to using the Hand-Held Display, confirm the area is free of hazardous gases.

Please confirm the area is free of hazardous conditions prior to opening the enclosure on the SensAir Toxic detector.

The hand-held display connects to the main board in the detector. Caution should be taken when plugging the display connector to the board. The connector is keyed and only installs one way. Once attached, it functions the same as the detector with display.

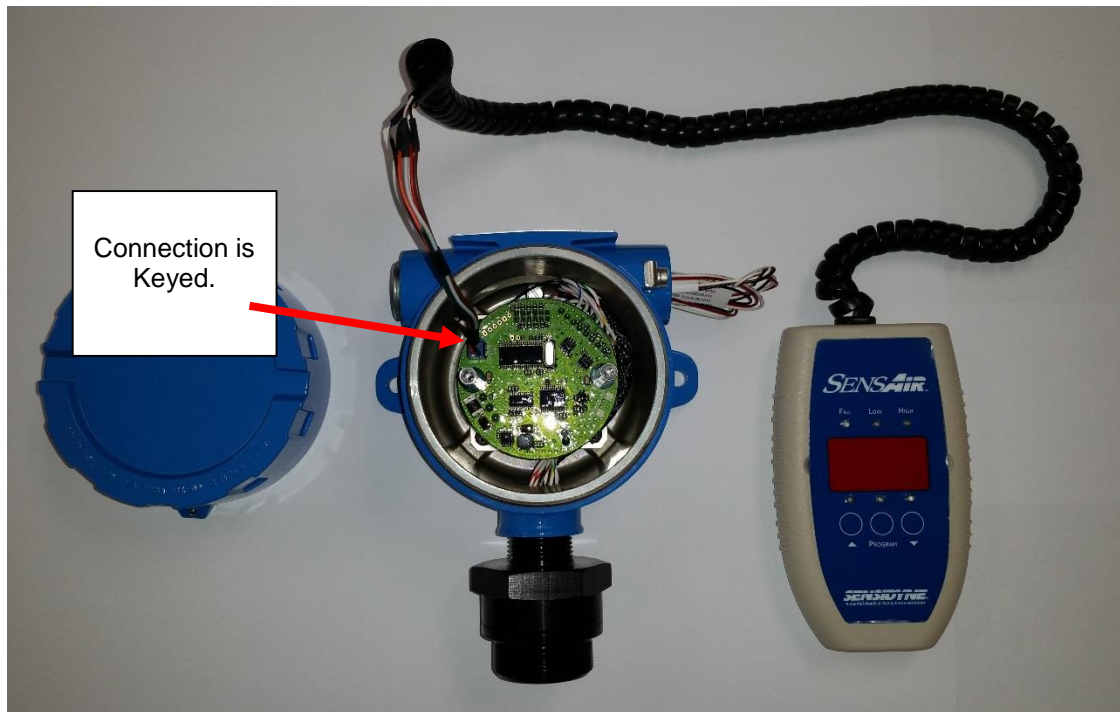
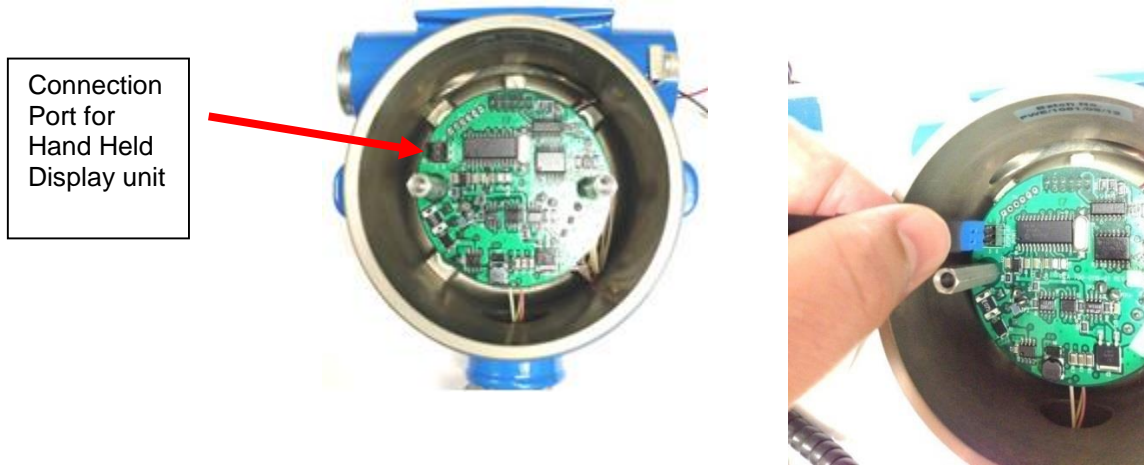

3.2.1 Electronics

The electronics inside the condulet consist of a display board (if installed), a power supply board and optional relay board. They are housed within the condulet, and converts the sensor response into a 4-20 mA current, linearly proportional to the concentration of the Toxic gas present at the sensor.

3.3 The Sensor Assembly

CAUTION: DO NOT attempt to install sensors from one type of SensAir Detector into another.

The sensor assembly consists of either a catalytic bead or electrochemical sensor.

Toxic sensors are electrochemical sensors designed to respond to the presence of a specific gas. Gas molecules permeate the sensor membrane and initiate an electrochemical reaction in the sensor. The sensor assembly consists of sealed sensor attached to a circuit board. A female connector mounted on top of the circuit board mates with a male connector mounted inside the sensor interface assembly.

WARNING: The Toxic sensor CANNOT be used to monitor for combustible hazards.

Catalytic Bead sensors detect a combustible gas before the concentration becomes potentially explosive. Gas molecules permeate the sensor flame arrestor and initiate a catalytic reaction in the sensor. Heat produced by this reaction is proportional to the concentration of the combustible gas. The heat produced is converted into an electrical signal which is monitored by the electronics. The sensor assembly consists of catalytic bead pellistor pair attached to a circuit board. A female connector mounted on top of the circuit board mates with a male connector mounted inside the sensor interface assembly. The sensor assembly is poison resistant and suitable for use where substances can inhibit or poison the sensor exist in low concentrations. The substances include:

- Silicon-containing compounds, such as silicone oils and greases (e.g., HMDS)
- Phosphorus-containing compounds, such as pesticides.
- Sulfur-containing compounds, such as carbon disulfide and hydrogen sulfide
- Halogen-containing compounds, such as fluoro- and chloro-carbons
- Lead-containing compounds, such as anti-knock petroleum additives
- Metal-containing hydride gases.

WARNING: The Combustible sensor CANNOT be used to monitor for toxic hazards.

4 Installation

4.1 Location

The SensAir Gas Detector is a local area monitor. It is imperative that the detector be located in an area where the greatest concentration of the target gas will be present in the shortest period of time after the occurrence of a leak or other increase in the concentration of the target gas in the atmosphere. Expert consultation may be necessary to determine the most optimum location for monitoring. In all circumstances, the plant safety officer or other appropriate personnel should be consulted before installation.

Site determination, at a minimum, must consider the following factors:

- most probable location of a leak
- physical properties of the target gas
- air convection in the area due to ventilation or ambient conditions
- operational environment
- presence of interferent gases

Ultimately, monitoring efficiency, and the degree of protection it affords, depends on the thoroughness of a detector placement survey.

4.2 Detector Installation (Enclosure)

Refer to all local electrical codes to ensure compliance for proper mounting.

The detector mounts to a wiring conduit via (19 mm) 3/4" female NPT at the conduit. To achieve a measure of RFI/EMI immunity, the enclosure and conduit must be grounded and shielded cable must be used.

The detector should be mounted with the sensor facing down to prevent moisture and debris from collecting on the sensor itself.

- 1) Get confirmation from the safety officer that the area is free of hazardous atmospheres.
- 2) For the metallic enclosure: Unscrew and remove the conduit cover. For the polymeric square enclosure: Remove the four corner screws to remove the cover.
- 3) Confirm that the input and output wires are without power and thread them through the opening of the housing.
- 4) Hold the wires out of the way and screw the conduit firmly into the conduit.
- 5) Cap the wires and replace the detector cover. For the polymeric square enclosure, secure all four corner screws that were removed if you are not going to wire the detector at this time.

NOTE:

Five full threads of engagement are required to maintain explosion-proof rating.

4.3 Detector Location

4.3.1 Wiring

Refer to all local electrical codes to ensure proper wiring compliance. The use of shielded wire is recommended.

NOTE:

The power supply must have a power source return isolated from earth ground. A Class 2 power supply must be used with GP version. Shielded cable is recommended with shield terminated to earth ground to ensure a measure of RFI/EMI immunity. If the metal conduit to which the detector is mounted is not earth grounded, the conduit must be earth grounded via the green wire.

The following sections provide specific information necessary to wire the detector to a power supply. A wiring diagram is provided to aid in wiring the detector to a power supply.

Three (3) wires are required to connect the detector to a Sensidyne controller, or a customer supplied 12-30 Vdc (Class 2 for GP) power supply and read-out device. See Figure 4.3.1 for wiring.

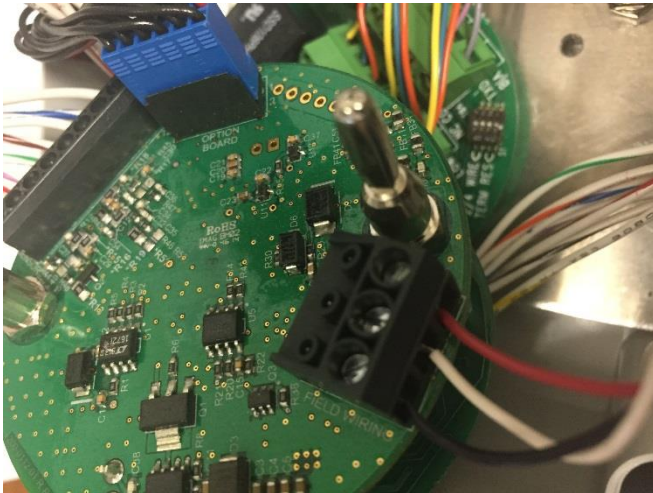

Bottom of Main PCA board showing Black, White and Red Wire connected.

4.3.2 Detector Wiring Diagram

⚠ Temperature rating of field wire must be equal to or above 85°C (185°F).

3-Wire Powered Unit

Power	V+	Red
4-20 Output	4-20 mA	White
Ground	RTN	Black

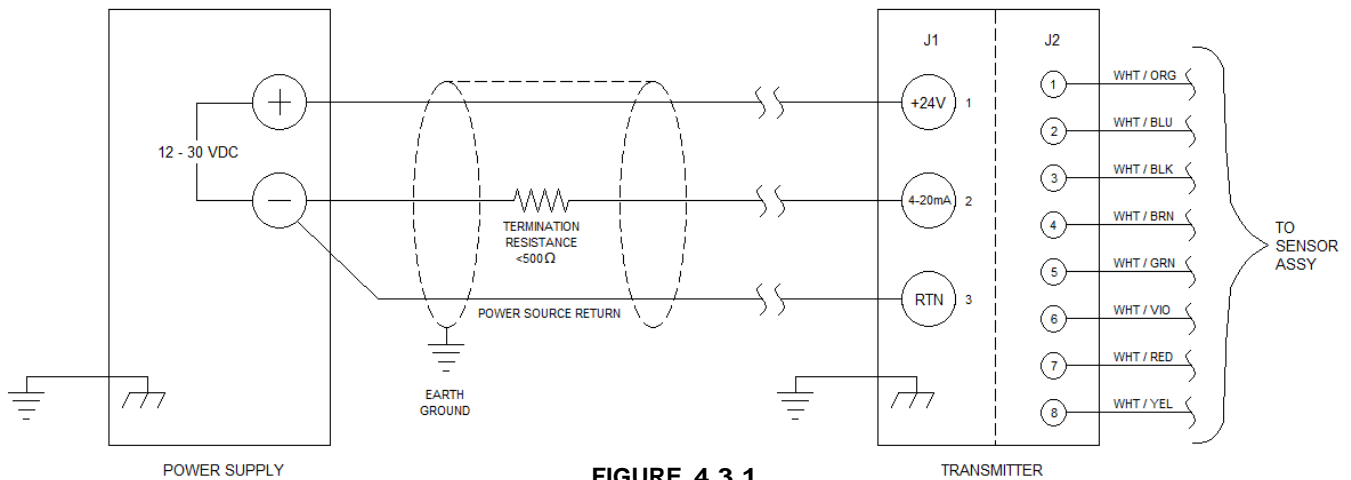

**FIGURE 4.3.1
DETECTOR WIRING**

4.3.3 Allowable Line Length

The maximum distance between the power supply and the detector is known as the allowable line length. It is a function of the power supply voltage, loop resistance, and termination resistance. This in turn determines allowable loop resistance and wire size.

Please refer to the table in the [Allowable Line Length Appendix](#) for the allowable line lengths for various wire sizes as well as the allowable loop resistance for various power supply voltages. The allowable voltage range for the power supply is 12-30 Vdc.

Up to 100 feet of wire with a minimum of 18 AWG may be used to remote mount the Combustible sensor from the display unit. Toxic and Oxygen sensors cannot be remote mounted.

At a supply voltage of 24 Vdc the maximum wire length between customer supplied controller and gas detector is 3,600 ft (1,100 m) with a minimum wire gauge of 20 AWG.

4.3.4 Remote Sensor Option

SensAir Combustible (*not Toxic or O₂*) can support a remote mounted sensor up to 100 feet if desired. Sensidyne can provide all remote mount hardware, but appropriate electrical elbows, nipples, cable glands and / or poured seals are required in addition to suitable conduit regardless of the supplier to maintain hazardous area installation approval requirements.

If ordered with the remote mount option, the SensAir Transmitter and Sensor Assembly are shipped separated and furnished with wire pigtailed for field wire termination. Sensidyne recommends the use of 4-conductor 18 AWG Belden 27326AS cable or equivalent by others. One of the four conductors will be unused and remain as a spare.

Wire termination of the remote sensor field wiring to J2 of the SensAir Transmitter shall be in accordance with the following Figure 4.3.2

After addition of remote cabling the Sensor Voltage must be readjusted to 2.000 +/- 0.005 Volts DC measured at the sensor using the AdJ menu.

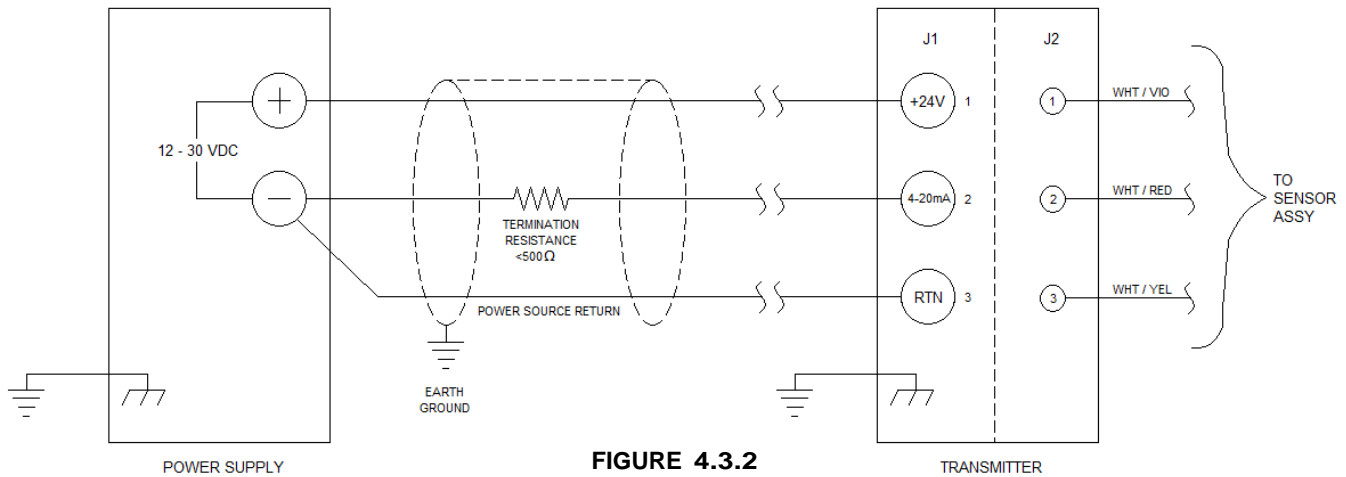

**FIGURE 4.3.2
DETECTOR WIRING**

4.3.5 Installation Procedure

Installers and Operators must read and understand the SensAir Manual prior to installation. Refer to all NEC/CEC and local electrical codes to ensure compliance for proper installation. The SensAir mounts to a wiring conduit via (19 mm) 3/4" female NPT at the enclosure. To achieve a measure of RFI/EMI immunity, the enclosure and conduit must be grounded and shielded cable must be used. Install a Circuit Breaker or switch near the unit for electric disconnect of all power conductors. Connect the power supply to 24VDC supply. Red wire (J1 Terminal 1) to V+ power, & White wire (J1 Terminal 2) to 4-20 (mA) output, & Black wire (J1 Terminal 3) to RTN. The Stainless-Steel Metal Enclosures and Blue Metal Enclosures contain a Grounding Clip on the exterior and Grounding Lug on the Interior Bottom Plate. The NEMA 4X Polymeric enclosure contains a Grounding Lug on the Interior Bottom Plate.

The detector terminals will not accept wire gauges larger than 14 AWG. 18 AWG is recommended as it is less rigid. In all cases, the connections must be clean, tight and protected from the weather. They must meet all required electrical codes. Remove factory supplied test wires. In order to maintain RF immunity, move all ferrites from test wires to user supplied wiring.

Field wire connections J1 and TB1 – TB4 (if option PCA installed) maximum wire gauges 16 AWG required torque 4 in/lbs.

Wire the detector as follows:

- 1) Get confirmation from the safety officer, or appropriate personnel, that the area is safe.
- 2) Verify that the conduit and the detector are securely connected together.
- 3) Verify that the input and output wires are (without power).
- 4) Unscrew and remove the condulet cover on the blue metal enclosure, or on the square plastic enclosure, remove the four corner screws to pull off the cover.
- 5) Verify that the total resistance of the wiring does not exceed the allowable loop resistance.
- 6) Install the ferrite beads on the field wires per the below figures, and then proceed to the next step.

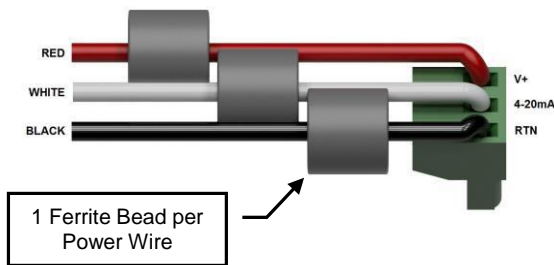

Figure 1 – Power Wires with Ferrite Beads Installed

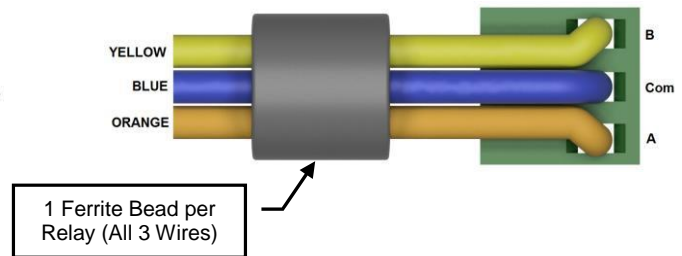

Figure 2 – Relay Wires with Ferrite Beads Installed

NOTE:

If wire size permits, loop wire through Ferrite Beads.

- 7) Attach and secure the power source return (negative lead) wire to the “RTN” Terminal (3) on the J1 connector.
- 8) Attach and secure the 4-20 mA output wire to the “4–20 mA” Terminal (2) on the J1 connector.
- 9) Attach and secure the positive lead wire to the “V+” Terminal (1) on the J1 connector.
- 10) Replace the conduit cover if not proceeding with start-up at this time.
- 11) Before applying power to the detector, verify that all connections are correct.
- 12) Go to Start-Up Section when you are ready to perform the start-up procedure.

5 Operation

NOTE:

The detector must be calibrated after initial installation and before normal operation is possible. ([See Calibration Section](#))

All Sensidyne gas detection equipment is functionally tested and calibrated with known zero and span gases before shipment to the customer. However, it is recommended that qualified personnel verify operation after initial installation using known zero and span gases. Repeat verification at 30 days and 60 days after initial installation, with deviations in zero and span recorded. The calibration or functional check interval can then be adjusted to suit that application's conditions. For further information, please consult the ISA Recommended Practices for gas detectors.

NOTE:

Catalytic Bead sensors are not "fail safe" therefore, monthly calibration is recommended.

Under normal operating conditions, the detector responds to the presence of gas by producing a 4-20 mA current that is linearly proportional to the concentration of gas present at the sensor.

5.1 Communication Modbus & BACnet Options

SensAir offers optional Modbus or BACnet communication protocols. Menu selections for the detector basic communication setup parameters can be found in the [Appendix Menu Map](#) sections 1.12 and 1.13. Detailed descriptions for integration parameters can be found in the [Modbus Appendix](#) and [BACnet Appendix](#) sections. Sensidyne recommends that only certified System Integrators manipulate or direct the changes to the detector setup parameters.

5.2 Output Current

When calibrated, the relationship between the output current of the detector (in mA) and the concentration of the target gas is linear. Concentration is shown as a Percentage of Full Scale.

SensAir Combustible is designed to respond similarly to most combustible gases at their respective Lower Explosive Limit (LEL) concentrations, despite the fact that these combustible substances may differ greatly in their concentrations as measured in %v (percent by volume) or ppm (parts per million).

For example, Methane becomes potentially explosive (100 %LEL) at a 5 %v (by volume) concentration, while n-Octane becomes potentially explosive (100%LEL) at a 1 %v concentration. Despite that the percent by volume concentrations of methane and n-octane are different, the response of the transmitter is the same to concentrations of methane and n-octane in %LEL scale.

[See Appendix - Combustible Selectivity Factors \(K-Factors\)](#) for LEL characteristics and approximate selectivity factors for many common combustible substances.

5.3 Sensor Interferents

Although highly selective for a particular gas, a sensor is not always completely specific. Certain sensor types will also respond to other gases, particularly if the other gases have similar physical/chemical properties. This "other" gas is called an interferent. Design and development makes every effort to identify and minimize these interferences.

NOTE:

Interferent Tables are intended for guidance only. For the most accurate measurements the detector should be calibrated using the intended target gas.

5.3.1 Combustible Flooding

Flooding occurs when there is exposure to flammable gas or vapor concentrations greater than 100 %LEL (regardless of the actual % by volume). The transmitter is not suitable for detection of combustible substances at any concentration greater than 100 %LEL. The catalytic device within the sensor assembly can be inhibited and damaged by exposure to such a large concentration. In the typical flooded response, the appearance of an output current greater than 20 mA occurs (as an over-range condition), followed closely by a decrease in the output current to values less than 20 mA. However, the following decrease in output current is NOT necessarily due to dissipation of the combustible substance.

Following a flooded response – when the area is safe – the transmitter must be re-calibrated in order to ensure that the sensor assembly has not been damaged. If calibration is not successful the catalytic device has been damaged and the sensor assembly must be replaced.

WARNING: Should an over-range condition occur, followed very closely by an apparent decrease in the concentration level, investigate the area. Consult the Safety Officer and CAUTIOUSLY and THOROUGHLY investigate before entering. A potentially explosive concentration of the combustible substance may still exist.

5.3.2 Combustible Inhibition and Poisoning

Inhibition and Poisoning occur when the combustible by-products from some compounds are deposited onto the catalytic device within the sensor assembly. These depositions will deactivate the sensor. The degree of deactivation may be either partial or complete, and may be either reversible or irreversible depending upon the concentration, and the duration of exposure to the interfering compound.

The sensor assembly should never be exposed to any of the following substances known to inhibit and poison the catalytic device:

- Silicon-containing compounds, such as silicone oils and greases
- Phosphorous-containing compounds, such as pesticides
- Sulfur-containing compounds, such as carbon disulfide and hydrogen sulfide
- Halogen-containing compounds, such as fluorocarbons and chlorocarbons
- Lead-containing compounds, such as anti-knock petroleum additives
- Metal-containing hydrides.
- Hydrocarbon compounds that polymerize and carburize on heating, such as styrene.

WARNING: Following exposure to a poisonous substance, the transmitter must be re-calibrated in order to assure that the sensor assembly has not been damaged. If calibration is not successful the catalytic device has been damaged and the sensor assembly must be replaced.

WARNING: After an exposure to a high concentration of combustible gas or poisonous substance, the user must perform a calibration to ensure proper operation of the device. Repair if needed.

CAUTION: Sensor operation maybe effected by oxygen-enriched or oxygen-deficient atmospheres.

5.3.3 Combustible Sensor K-Factor Adjustment

[See Appendix - Combustible Selectivity Factors \(K-Factors\)](#) to select the appropriate factor. To adjust K-Factor

User controls are 3 magnetic switches labeled ▼ (DOWN), ▲ (UP) and "Program".

- Hold "Program" for 2 seconds.
- ZrO will appear.
- Continue to hold "Down" until FCt appears.
- Hold "Program" for 2 seconds to select.
- Present K Factor will appear and High Alarm LED will light.
- Using the Up / Down arrows the gas concentration will change once a second. The limits are 3.0 and 0.5.
- Hold "Program" for 2 seconds to save the K Factor, or no user action for 20 seconds and the K Factor will revert to the previous value.
- Unit will return to the normal screen

6 Start Up Procedure

It is necessary to perform the following start up procedure upon initial installation. Performance of the startup procedure is not ordinarily required at the time of routine periodic calibration. However, the startup procedure should be performed when any of the following occurs:

- loss of power for an extended period time
- upon sensor assembly replacement
- following a flooded response

WARNING: The safety officer must ensure that the area is safe before the conduit may be opened.

- 1) Unscrew and remove the conduit cover.
- 2) Verify the detector has been wired properly.
- 3) Apply power to the detector. Observe that the Display has proper indications. If the Display does not have proper indication go to [Appendix Troubleshooting Guide](#) to determine the cause of the problem.

CAUTION: Do not continue with the start-up procedure until this problem has been corrected.

- 4) Allow the detector to warm up.
- 5) Replace the conduit cover. Allow the unit to stabilize for at least 1 hour before calibrating the detector.
- 6) If unit is a Remote mounted sensor, using the AdJ menu adjust the voltage at the sensor to be 2.000 +/- 0.005 Volts DC.
- 7) The SensAir Gas Detector must be calibrated prior to initial use and at regular intervals thereafter. In addition, the calibration procedure must be performed if any of the following conditions occur:
 - loss of power for an extended period of time
 - detector is over-ranged or flooded
 - sensor assembly is replaced

Failure to maintain this schedule could result in impaired system performance and/or erroneous readings.

NOTE:

If calibration is being performed prior to initial use or after sensor replacement, the detector must be allowed to stabilize with power applied for 1 hour before attempting the calibration procedure.

All Sensidyne gas detection equipment is functionally tested and calibrated with known zero and span gases before shipment to the customer. However, it is recommended that qualified personnel verify operation after initial installation using known zero and span gases.

For further information on industry standards for sensor calibration, please refer to *Recommended Practice for the Installation, Operation, and Maintenance of Combustible Gas Detection Instruments* (ANSI/ISA TR12.13.02-2003) published by the ISA.

NOTE:

The calibration procedure should be performed at ambient conditions including altitude, with special attention paid to the humidity and temperature requirements of the detector. Zeroing must be performed prior to Calibration.

7 Calibration

7.1 Equipment

Calibration Gas

Sensidyne offers a full line of equipment for properly calibrating the SensAir Toxic Gas Detector. Calibration equipment available for the Toxic Gas Detector is described below. Refer to [Appendix Calibration Equipment](#) for ordering information, and for a complete listing of available calibration equipment and accessories. Each calibration gas cylinder is shipped with an MSDS sheet (a NIST traceable calibration certificate also is available upon request).

- Regulator, part number 580-0001-01 (0.5 LPM regulator is recommended.)
- Calibration Cup, part number 821-0611-01-R, or if Sensor Shield is used, Cal Plug is pn 821-0223-01
- Magnetic Screwdriver, part number 7013201-1
- Hand Held Display (if using the detector without built in display), part number 821-0701-01-R
- Calibration Gas bottle based on the sensor: see [Appendix](#) for listing of gas bottles

7.2 Zeroing (Toxic and Combustible Only)

User controls are 3 magnetic switches labeled ▼ (DOWN), ▲ (UP) and "Program".

- Hold "Program" for 2 seconds
- ZrO will appear
- Hold "Program" for 2 seconds to select
- "Up" arrow LED will light. Zeroing of detector taking place
- After 60 seconds, "Up" arrow LED will go out signifying Zeroing is complete.

7.3 Select Calibration Gas Concentration

User controls are 3 magnetic switches labeled ▼ (DOWN), ▲ (UP) and "Program".

- Hold "Program" for 2 seconds
- ZrO will appear
- Hold "Down" until GAS appears
- Hold "Program" for 2 seconds to select
- Saved Calibration Gas Concentration will appear
- Use "Up" and "Down" to adjust the Calibration Gas Concentration if needed
- Hold "Program" for 2 seconds to save new gas concentration

7.4 Calibration Procedure

For Catalytic Pellistors – Calibration should be no less often that once every 90 days or when sensor is exposed to gas (ATEX and IECEx only).

User controls are 3 magnetic switches labeled ▼ (DOWN), ▲ (UP) and "Program".

- Hold "Program" for 2 seconds
- ZrO will appear
- Hold "Down" for 1 second
- CAL will appear
- Hold "Program" for 2 seconds to select
- Down arrow LED will light (calibrating detector). To Escape calibration mode, hold "UP" for 15 seconds
- Apply gas
- After 60 seconds of stable gas, "Down" arrow LED will go out and calibration is complete
- Pass or Failure code will appear
- Remove gas
- Normal display will return after test gas dissipates

NOTE:

Failure to Zero or Calibrate is an indication that the sensor may have reached the end of its life.

Warning: DO NOT operate this product should it malfunction or require repair. Operation of a malfunctioning product, or a product requiring repair may result in serious personal injury or death.

7.5 4 to 20 mA Adjustment

All SensAir Detectors provide a 4 to 20 mA primary output. This output signal is tunable to specific systems load resistance to ensure the proper concentration and fault signal representation. The below steps should be utilized during commissioning to check or tune the 4 to 20 mA primary output.

WARNING: The safety officer must ensure that the area is safe before the conduit is opened AND the safety system is properly configured for this routine.

- Ensure the detector powered on.
- Unscrew and remove the conduit cover.
- Dismount the Display PCA and connect volt meter to the test leads as pictured below.

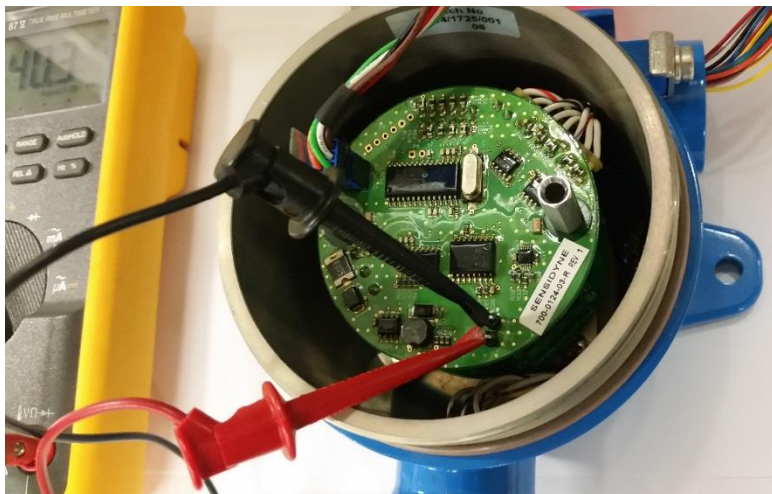



- Set voltmeter to millivolts.
- The voltmeter will display an equivalent value for the mA signal in mV. A 40 mV reading equals 4 mA, and a 200 mV reading equals 20 mA. The volt meter should display a value close to 40 mV at this step. If not within 1 mV, confirm proper field wire termination and system load-resistance within 100Ω to 500Ω.
- The Display PCA can be temporarily remounted with the voltmeter leads connected to complete the procedure.

User controls are 3 magnetic switches labeled ▼ (DOWN), ▲ (UP) and "Program".

- Hold "Program" for 2 seconds
- ZrO will appear
- Hold "Down" for 4 seconds until "A 4" is displayed
- Hold "Program" for 2 seconds
- "- - -" will appear
- Using the Up / Down arrows, adjust the 4 mA output until the voltmeter reads "40 mV".
- Hold "Program" for 2 seconds. The detector will return to normal operation.
- Hold "Program" for 2 seconds.
- Hold "Down" for 5 seconds until "A20" is displayed
- Hold "Program" for 2 seconds
- "- - -" will appear
- Using the Up / Down arrows, adjust the 20 mA output until the voltmeter reads "200 mV".
- Hold "Program" for 2 seconds. The detector will return to normal operation.

8 Maintenance

The Sensidyne SensAir Gas Detector does not require any periodic maintenance beyond sensor calibration unless a malfunction occurs. In the event of a malfunction, refer to [Appendix Troubleshooting Guide](#). Use the Troubleshooting Guide to determine the cause of and remedy for common problems which may occur in the field.

8.1 Sensor replacement:

Read and understand the Operation & Service Manual for your gas detector before installation. List of replacement sensors located in [Appendix Accessories and Spares](#). The disposable sensor assembly should be replaced if it is damaged or when it no longer performs properly.

- Remove power from the gas detector.
- Remove the two set screws securing the sensor retainer assembly to the holder assembly.
- Unscrew the sensor retainer assembly from the holder assembly.
- Gently pull the sensor assembly from the holder assembly.
- Install the replacement sensor.
- Reinstall sensor retainer assembly.
- Reinstall and tighten the two set screws to secure the sensor retainer assembly to the holder assembly.
- Apply power to the gas detector.
- If Combustible sensor adjust sensor voltage to 2.000 +/- 0.005 Volts DC.
- Perform calibration procedure.

8.2 Sensor Assembly Replacement

CAUTION: The safety officer must ensure that the area is safe before the conduit is opened.

- Remove power from the detector.
- Unscrew and remove the conduit cover.
- Disconnect the 8 colored wires from the sensor interface assembly on the electronics module PCB
- Remove the rainshield if one is attached. Unscrew and remove the old sensor assembly from the lower opening of the conduit.
- Discard/recycle the old assembly.
- Thread the eight colored wires from the new sensor interface assembly through the lower opening of the conduit.

- Orange
- Blue
- Black
- Brown
- Green
- Violet
- Red
- Yellow

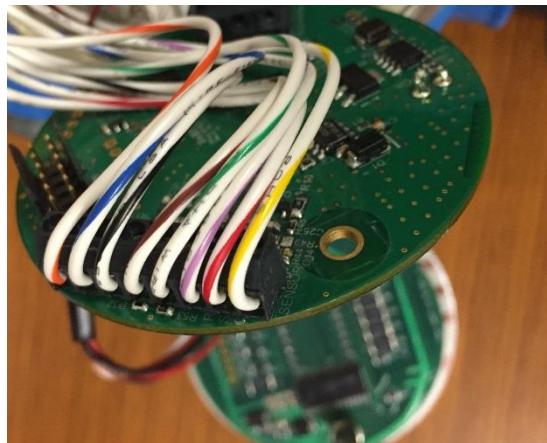

- Apply sealant to the threads of the new sensor assembly housing to ensure a watertight seal and prevent seizing. Silicone based sealant must never be used on or near these sensors. Conductive pipe dope is recommended.
- Screw the new sensor assembly firmly into place.

SensAir Toxic Gas Detector

- Connect and secure the eight wires (3 wires for Combustible sensor) onto the electronics module PCB noting the wire designation.

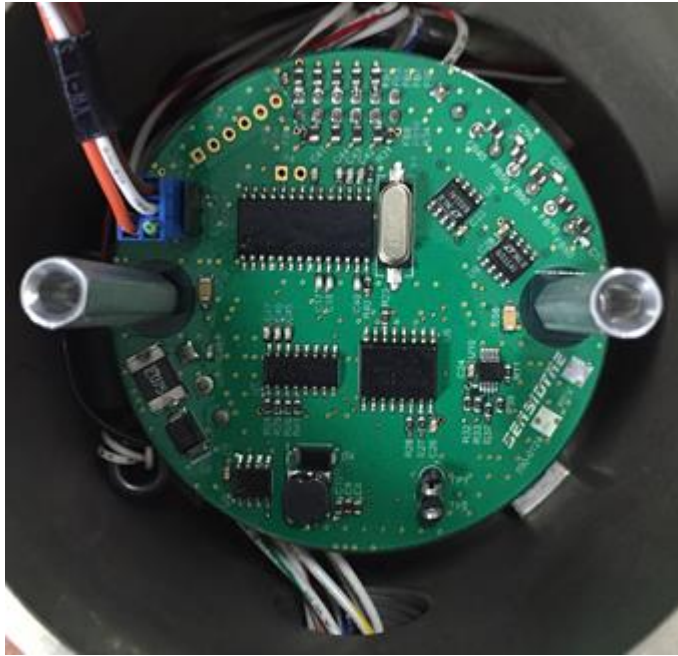

- Top of Main PCA shown above in the proper orientation with the connection to Display PCA.
- Verify all wiring is secure.
- Replace and secure the condulet cover. Confirm the condulet o-ring is properly seated when tightening the condulet. Allow the detector to warm up for at least 1 hour before placing into operation.

9 Appendix- Menu Map

The setup and operation of the SensAir Toxic is controlled by parameters and procedures that are accessed through the menu structure.

Menu Map

1. Detector Modes

1.1. Zeroing

- 1.1.1. Hold "Program" for 2 seconds.
- 1.1.2. **ZrO** will appear.
- 1.1.3. Hold "Program" for 2 seconds to select.
- 1.1.4. Up arrow LED will light (zeroing detector).
- 1.1.5. After 60 seconds Up arrow LED will go out (zeroing completed).

1.2. Calibration

- 1.2.1. Hold "Program" for 2 seconds.
- 1.2.2. **ZrO** will appear.
- 1.2.3. Hold "Down" for 1 second.
- 1.2.4. **CAL** will appear.
- 1.2.5. Hold "Program" for 2 seconds to select.
- 1.2.6. Down arrow LED will light (calibrating detector), if "Up" held for 15 seconds escape calibration mode.
- 1.2.7. Apply gas, if "Up" held for 15 seconds escape calibration mode.
- 1.2.8. After 60 seconds of stable gas, the down arrow LED will go out (calibration completed).
- 1.2.9. Pass or Failure Code will appear.
- 1.2.10. Remove gas.
- 1.2.11. Normal display will return after test gas dissipates.

1.3. Calibration Gas Concentration

- 1.3.1. Hold "Program" for 2 seconds.
- 1.3.2. **ZrO** will appear.
- 1.3.3. Continue to hold "Down" until **GAS** appears.
- 1.3.4. Hold "Program" for 2 seconds to select.
- 1.3.5. Present calibration gas concentration will appear and High Alarm LED will light.
- 1.3.6. Using the Up / Down arrows the gas concentration will change once a second.
- 1.3.7. Hold "Program" for 2 seconds to save gas concentration, or no user action for 20 seconds and the gas concentration will revert to the previous value.
- 1.3.8. Unit will return to the normal screen.

1.4. Hold Current Loop

- 1.4.1. Hold "Program" for 2 seconds.
- 1.4.2. **ZrO** will appear.
- 1.4.3. Continue to hold "Down" until **HOd** appears.
- 1.4.4. Hold "Program" for 2 seconds to select.

1.5. Adjust 4 – 20 mA current loop 4 mA setpoint

- 1.5.1. Hold "Program" for 2 seconds.
- 1.5.2. **ZrO** will appear.

- 1.5.3. Continue to hold “Down” until **A 4** appears.
- 1.5.4. Hold “Program” for 2 seconds to select.
- 1.5.5. Three dashes will appear and High Alarm LED will light.
- 1.5.6. Using the Up / Down arrows the 4 mA setpoint will change every 0.2 seconds.
- 1.5.7. Hold “Program” for 2 seconds to save the setpoint, or no user action for 20 seconds and the setpoint will revert to the previous value.
- 1.5.8. Unit will return to the normal screen.

1.6. Adjust 4 – 20 mA current loop 20 mA setpoint

- 1.6.1. Hold “Program” for 2 seconds.
- 1.6.2. **ZrO** will appear.
- 1.6.3. Continue to hold “Down” until **A20** appears.
- 1.6.4. Hold “Program” for 2 seconds to select.
- 1.6.5. Three dashes will appear and High Alarm LED will light.
- 1.6.6. Using the Up / Down arrows the 20 mA setpoint will change every 0.2 seconds.
- 1.6.7. Hold “Program” for 2 seconds to save the setpoint, or no user action for 20 seconds and the setpoint will revert to the previous value

If Option Board is present the following menu items will be available.

1.7. Current Loop Fault Enable

- 1.7.1. Hold “Program” for 2 seconds
- 1.7.2. **ZrO** will appear
- 1.7.3. Continue to hold “Down” until **CUL** appears
- 1.7.4. Hold “Program” for 2 seconds to select
- 1.7.5. If fault enabled, **ECL** will appear. If fault not enabled **nCL** will appear
- 1.7.6. Holding “Program” for 2 seconds will change the state of the enable. From Enabled to Not Enabled or Not Enabled to Enabled
- 1.7.7. No user action for 20 seconds and the state of enable will remain the same.

1.8. Low Alarm Set Point.

- 1.8.1. Hold “Program” for 2 seconds
- 1.8.2. **ZrO** will appear
- 1.8.3. Continue to hold “Down” until **ALO** appears
- 1.8.4. Hold “Program” for 2 seconds to select
- 1.8.5. Present Low Alarm Set Point will appear and Low Alarm LED will flash
- 1.8.6. Using the Up / Down arrows the Low Alarm Set Point will change once a second. The limits are 10 to 60 % of full scale or the maximum value of the High Alarm setting. Oxygen limits are 19.5 to 15.0 %Vol or the minimum value of the Low Low Alarm setting.
- 1.8.7. Hold “Program” for 2 seconds to save the set point, or no user action for 20 seconds and the set point will revert to the previous value.

1.9. Low Low Alarm Set point (Oxygen Only)

- 1.9.1. Hold “Program” for 2 seconds
- 1.9.2. **ZrO** will appear
- 1.9.3. Continue to hold “Down” until **ALL** appears
- 1.9.4. Hold “Program” for 2 seconds to select
- 1.9.5. Present Low Low Alarm Set Point will appear and Low Low Alarm LED will Flash

1.9.6. Using the Up / Down arrows the Low Low Alarm Set Point will change once a second. The limits are 19.5 to 15.0 %Vol or the maximum value of the Low Alarm setting

1.9.7. Hold "Program" for 2 seconds to save the set point, or no user action for 20 seconds and the set point will revert to the previous value.

1.10. High Alarm Set Point (Toxic and Combustible Only)

1.10.1. Hold "Program" for 2 seconds

1.10.2. **ZrO** will appear

1.10.3. Continue to hold "Down" until **AHI** appears

1.10.4. Hold "Program" for 2 seconds to select

1.10.5. Present High Alarm Set Point will appear and High Alarm LED will Flash

1.10.6. Using the Up / Down arrows the High Alarm Set Point will change once a second. The limits are 10 to 60 % full scale or the maximum value of the High Alarm setting

1.10.7. Hold "Program" for 2 seconds to save the set point, or no user action for 20 seconds and the set point will revert to the previous value.

1.11. Low Relay Settings

1.11.1. Hold "Program" for 2 seconds

1.11.2. **ZrO** will appear

1.11.3. Continue to hold "Down" until **rLO** appears

1.11.4. Hold "Program" for 2 seconds to select

1.11.5. If Low Relay Latching is enabled **LAC** will appear if not enabled **nLA** will appear

1.11.6. Holding "Program" for 2 seconds will change the state of enable. From Latching to Not Latching or Not Latching to latching

1.11.7. No user action for 20 seconds and the state of enable will remain the same

1.11.8. Hold "Down" to display Energize state of the Low Relay

1.11.9. If relay is not energized **nEn** will appear, if energized **Enr** will appear

1.11.10. Holding "Program" for 2 seconds will change the state of the energize. From Energize to Not Energized or Not Energized to Energize.

1.11.11. No user action for 20 seconds and the state of the energize will remain the same.

1.12. Low Low Relay Settings (Oxygen Only)

1.12.1. Hold "Program" for 2 seconds

1.12.2. **ZrO** will appear

1.12.3. Continue to hold "Down" until **rLL** appears

1.12.4. Hold "Program" for 2 seconds to select

1.12.5. If Low Low Relay Latching is enabled **LAC** will appear if not enabled **nLA** will appear

1.12.6. Holding "Program" for 2 seconds will change the state of the enable. From Latching to Not Latching or Not Latching to Latching

1.12.7. No user action for 20 seconds and the state of enable will remain the same

1.12.8. Hold "Down" to display Energize state of the Low Low Relay

1.12.9. If relay is not energized **nEn** will appear, if energized **Enr** will appear

1.12.10. Holding "Program" for 2 seconds will change the state of the energize. From Energize to Not Energized or Not Energized to Energize

1.12.11. No user action for 20 seconds and the state of the energize will remain the same.

1.13. High Relay Settings (Toxic and Combustible Only)

- 1.13.1. Hold "Program" for 2 seconds
- 1.13.2. **ZrO** will appear
- 1.13.3. Continue to hold "Down" until **rHI** appears
- 1.13.4. Hold "Program" for 2 seconds to select
- 1.13.5. If High Relay Latching is enabled **LAC** will appear if not enabled **nLA** will appear
- 1.13.6. Holding "Program" for 2 seconds will change the state of the enable. From Latching to Not Latching or Not Latching to Latching
- 1.13.7. No user action for 20 seconds and the state of enable will remain the same
- 1.13.8. Hold "Down" to display Energize state of the High Relay
- 1.13.9. If relay is not energized **nEn** will appear, if energized **Enr** will appear
- 1.13.10. Holding "Program" for 2 seconds will change the state of the energize. From Energize to Not Energized or Not Energized to Energize
- 1.13.11. No user action for 20 seconds and the state of the energize will remain the same.

1.14. Adjust Modbus or BACnet Address

- 1.14.1. Hold "Program" for 2 seconds
- 1.14.2. **ZrO** will appear
- 1.14.3. Continue to hold "Down" until **AdS** appears
- 1.14.4. Hold "Program" for 2 seconds to select
- 1.14.5. Present Modbus address will appear and High Alarm LED will flash
- 1.14.6. Using the Up / Down arrows the Modbus address will change once a second. The limits are 1 and 248
- 1.14.7. Hold "Program" for 2 seconds to save the address, or no user action for 20 seconds and the address will revert to the previous value
- 1.14.8. Unit will return to the normal screen

1.15. Adjust Modbus or BACnet Baud Rate

- 1.15.1. Hold "Program" for 2 seconds
- 1.15.2. **ZrO** will appear
- 1.15.3. Continue to hold "Down" until **baU** appears
- 1.15.4. Hold "Program" for 2 seconds to select
- 1.15.5. Present Modbus baud rate will appear and High Alarm LED will flash
- 1.15.6. Using the Up / Down arrows select the desired baud rate from the 3 selections (9.6 for 9600, 19.2 for 19200, or 38.4 for 38400)
- 1.15.7. Hold "Program" for 2 seconds to save the baud rate, or no user action for 20 seconds and the baud rate will revert to the previous value
- 1.15.8. Unit will return to the normal screen.

1.16. Adjust K Factor

- 1.16.1. Hold "Program" for 2 seconds.
- 1.16.2. **ZrO** will appear.
- 1.16.3. Continue to hold "Down" until **FcT** appears.
- 1.16.4. Hold "Program" for 2 seconds to select.
- 1.16.5. Present K Factor will appear and High Alarm LED will light.
- 1.16.6. Using the Up / Down arrows the gas concentration will change once a second. The limits are 3.0 and 0.5.

1.16.7. Hold "Program" for 2 seconds to save the K Factor, or no user action for 20 seconds and the K Factor will revert to the previous value.

1.16.8. Unit will return to the normal screen.

1.17. Sensor Voltage Adjust

1.17.1. The sensor voltage must be adjusted anytime the sensor is replaced in the main transmitter. The voltage at the sensor must be maintained at 2.000 +/- 0.005 Volts DC.

1.17.2. If the sensor voltage is adjusted the sensor must be re-zeroed and calibrated.

1.17.3. Hold "Program" for 2 seconds.

1.17.4. ZrO will appear.

1.17.5. Continue to hold "Down" until AdJ appears.

1.17.6. Hold "Program" for 2 seconds to select.

1.17.7. Three dashes will appear and High Alarm LED will light.

1.17.8. Using the Up / Down arrows the sensor voltage will change every 0.2 seconds.

1.17.9. Hold "Program" for 2 seconds to save the sensor voltage, or no user action for 20 seconds and the sensor voltage will revert to the previous value.

1.17.10. Unit will return to the normal screen.

10 Appendix- Fault Codes

F00 – Not Assigned

F01 – Sensor Failed (Oxygen reverts to 0.0 on the display)

F02 – Cal Mode Calibration Fail, outside gain range

F03 – Cal Mode Gas not present after 5 minutes, User aborted calibration

F04 – Cal Mode Gas not stable after 5 minutes, User aborted calibration

F05 – Zero Mode Failed

F06 – Missing Sensor

11 Appendix- Dimensional Drawings

11.1 Dimensions

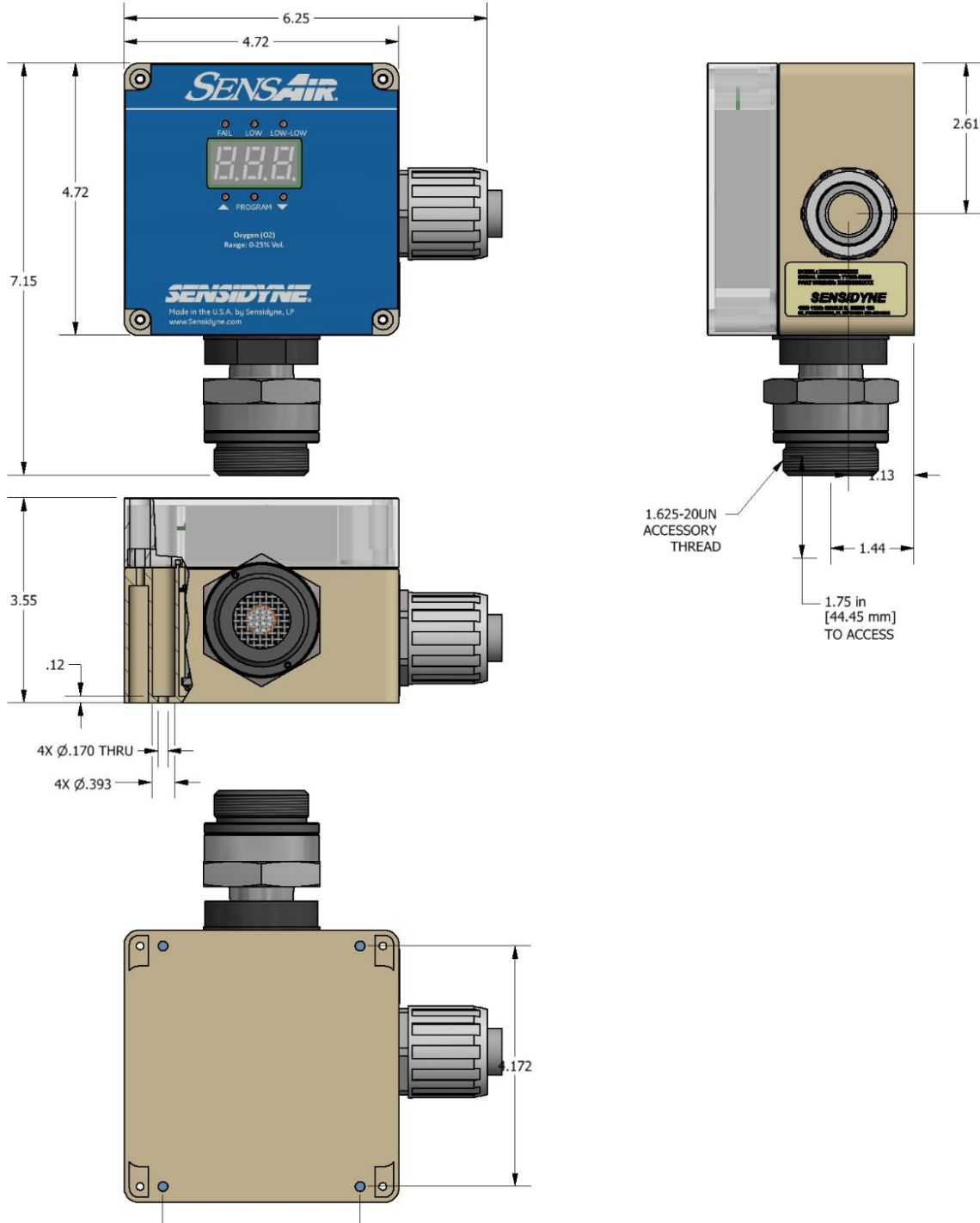

SensAir Toxic Gas Detector

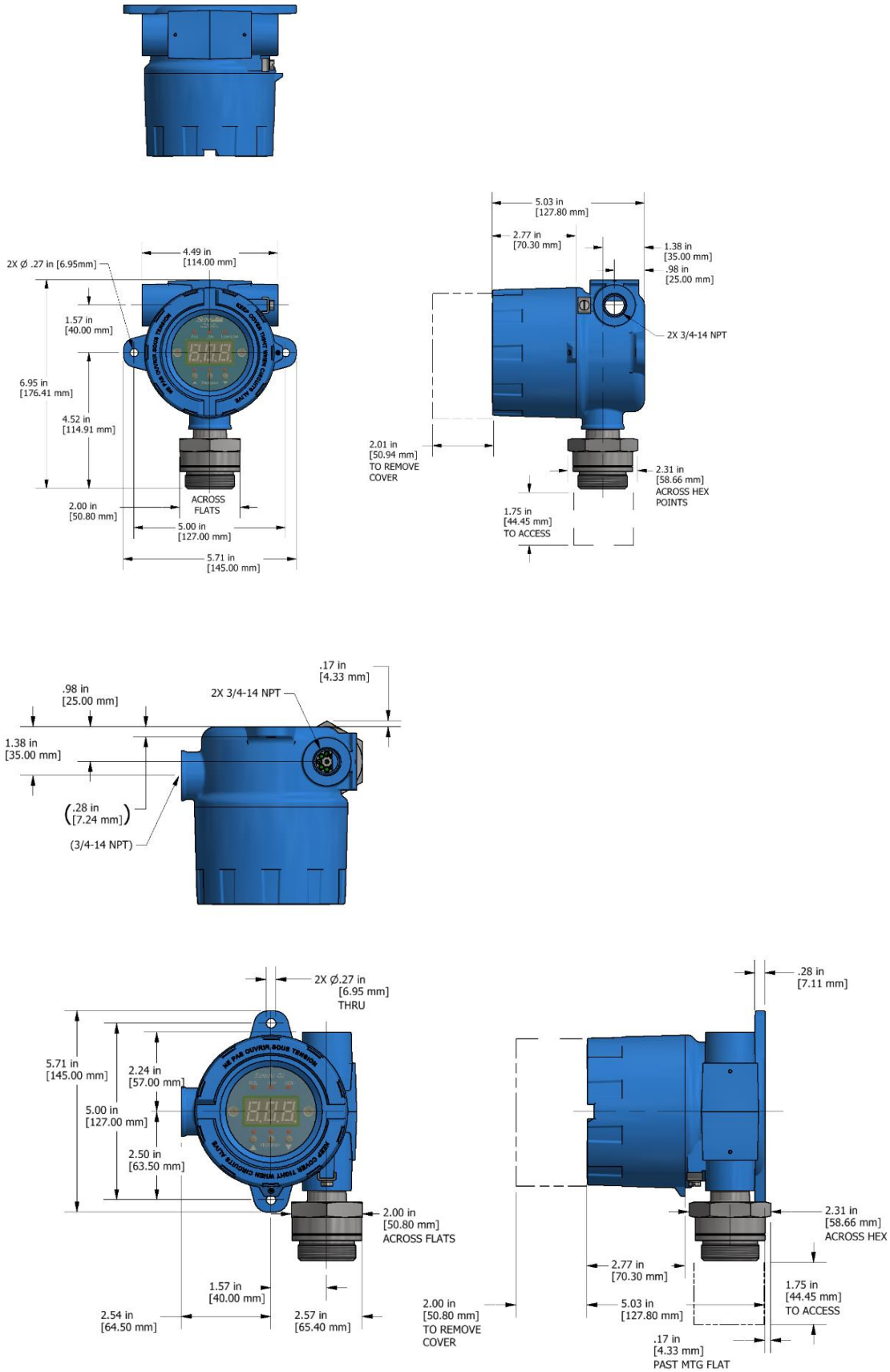

12 Appendix- Calibration Equipment

Product Number	Description
580-0001-01	Regulator (0.5 LPM), for use with all gases
7010032-1	PVC Carrying Case (holds two gas cylinders, plus regulator, tubing & fitting)
821-0604-01	Calibration Cup
821-0223-01	Calibration Plug, used when a sensor shield is installed
7016042	Tygon® Tubing, 3/16" ID x 5/16", sold per foot, not for use with reactive gases
7015551	Teflon® Tubing, sold per foot, (recommend 3ft for cal, Use with Cl ₂ , HCL, HF, NO ₂ , SO ₂)
580-0013-01	Cylinder Recycling Tool

Zero Calibration Gases

Product Number	Description
009824-15	Zero Gas for Oxygen (O ₂) or Infrared sensors, 100% Nitrogen (103L)
009824-25	Zero Gas for all other sensors including Infrared, 20.9% O ₂ in N ₂ (103L)

Calibration Gases

All calibration gases are in Aluminum or Steel cylinders containing either 58 SL or 103 SL of gas. Gas is shipped with a Material Safety Data Sheet (MSDS). A NIST traceable calibration certificate is available upon request. Please contact Sensidyne for other gases that might be available.

Product Number	Description
009824-57	Ammonia, NH ₃ , 25 ppm in Nitrogen (58 SL)
009824-38	Ammonia, NH ₃ , 50 ppm in Nitrogen (58 SL)
009824-67	Ammonia, NH ₃ , 300 ppm in Nitrogen (58 SL)
009824-78	Ammonia, NH ₃ , 150 ppm in Nitrogen (58 SL)
009824-4	Carbon Monoxide, CO, 50 ppm in Nitrogen (103 SL)
009824-65	Carbon Monoxide, CO, 100 ppm in Nitrogen (103 SL)
009824-18	Carbon Monoxide, CO, 250 ppm in Air (103 SL)
009824-53	Chlorine, Cl ₂ , 2 ppm in Nitrogen (58 SL)
009824-34	Chlorine, Cl ₂ , 5 ppm in Nitrogen (58 SL)
009824-44	Chlorine, Cl ₂ , 10 ppm in Nitrogen (58 SL)
009824-41	Chlorine, Cl ₂ , 50 ppm in Nitrogen (58 SL)
009824-60	Ethylene Oxide, C ₂ H ₄ O, 5 ppm in Nitrogen (103 SL)
009824-16	Hydrogen, H ₂ , 500 ppm in Air (103 SL)
009824-6	Hydrogen, H ₂ , 2 %vol / 50 %LEL in Air (103 SL)
009824-56	Hydrogen Chloride, HCl, 5 ppm in Nitrogen (58SL)
009824-37	Hydrogen Chloride, HCl, 10 ppm in Nitrogen (58SL)
009824-42	Hydrogen Chloride, HCl, 50 ppm in Nitrogen (58SL)
009824-54	Hydrogen Cyanide, HCN, 10 ppm in Nitrogen (58SL)
009824-79	Hydrogen Cyanide, HCN, 25 ppm in Nitrogen (58SL)
009824-80	Hydrogen Cyanide, HCN, 50 ppm in Nitrogen (58SL)
009824-55	Hydrogen Sulfide, H ₂ S, 5 ppm in Nitrogen (58L)
009824-9	Hydrogen Sulfide, H ₂ S, 10 ppm in Nitrogen (58SL)

SensAir Toxic Gas Detector

009824-33	Hydrogen Sulfide, H ₂ S, 25 ppm in Nitrogen (58SL)
009824-10	Hydrogen Sulfide, H ₂ S, 50 ppm in Nitrogen (58SL)
009824-35	Nitric Oxide, NO, 30 ppm in Nitrogen (58L)
009824-43	Nitrogen Dioxide, NO ₂ , 5 ppm in Nitrogen (103SL)
009824-36	Nitrogen Dioxide, NO ₂ , 10 ppm in Nitrogen (103SL)
009824-25	Oxygen, O ₂ , 20.9 %vol in Nitrogen (103SL)
009824-58	Phosphine, PH ₃ , 0.5 ppm in Nitrogen (58SL)
009824-73	Phosphine, PH ₃ , 5 ppm in Nitrogen (58SL)
009824-59	Silane, SiH ₄ , 5 ppm in Nitrogen (58SL)
009824-8	Sulfur Dioxide, SO ₂ , 5 ppm in Nitrogen (58SL)
009824-39	Sulfur Dioxide, SO ₂ , 10 ppm in Nitrogen (58SL)
009824-17	Sulfur Dioxide, SO ₂ , 50 ppm in Nitrogen (58SL)

13 Appendix – Accessories and Spares

Product Number	Description
821-0610-01-R	Sensor Shield <i>(allows use of standard Plus Series Calibration Plug)</i>
821-0611-01-R	Calibration Cup
821-0223-01	Plus Series Calibration Plug <i>(for use when sensor shield is used)</i>
821-0612-01-R	Flow Block <i>(for use with Sample Draw)</i>
821-0614-01-R	Duct Mount
821-0615-02-R	Adapter Accessory <i>(allows use of standard Plus Series Rainshield & Splashguard)</i>
821-0203-02	Plus Series Rainshield with calibration port <i>(not for use with reactive gases NH₃, SO₂, HCl, NO₂, HF)</i>
821-0229-01	Plus Series Splashguard <i>(for use with reactive gases NH₃, SO₂, HCl, NO₂, HF)</i>
821-0701-01-R	Hand Held Remote Programmer <i>(for use with SensAir with no display)</i>
823-1001-11-R	Replacement Oxygen (O ₂) Sensor
823-1002-11-R	Replacement Hydrogen Sulfide (H ₂ S) 50 ppm Sensor
823-1003-11-R	Replacement Hydrogen Sulfide (H ₂ S) 100 ppm Sensor
823-1004-11-R	Replacement Ammonia (NH ₃) 50 ppm Sensor
823-1005-11-R	Replacement Ammonia (NH ₃) 100 ppm Sensor
823-1006-11-R	Replacement Ammonia (NH ₃) 300 ppm Sensor
823-1007-11-R	Replacement Carbon Monoxide (CO) 100 ppm Sensor
823-1023-11-R	Replacement Carbon Monoxide (CO) 250 ppm Sensor
823-1008-11-R	Replacement Carbon Monoxide (CO) 500 ppm Sensor
823-1009-11-R	Replacement Carbon Monoxide (CO) 1,000 ppm Sensor
823-1010-11-R	Replacement Chlorine (Cl ₂) 5 ppm Sensor
823-1011-11-R	Replacement Chlorine (Cl ₂) 10 ppm Sensor
823-1012-11-R	Replacement Hydrogen Chlorine (HCl) 10 ppm Sensor
823-1013-11-R	Replacement Hydrogen Chlorine (HCl) 100 ppm Sensor
823-1014-11-R	Replacement Nitrogen Dioxide (NO ₂) 10 ppm Sensor
823-1015-11-R	Replacement Hydrogen (H ₂) 1,000 ppm Sensor <i>(electrochemical)</i>
823-1016-11-R	Replacement Cyanide (HCN) 20 ppm Sensor
823-1017-11-R	Replacement Hydrofluoric Acid (HF) 10 ppm Sensor
823-1018-11-R	Replacement Sulfur Dioxide (SO ₂) 20 ppm Sensor
823-1019-11-R	Replacement Chlorine Dioxide (ClO ₂) 5 ppm Sensor
823-1020-11-R	Replacement Combustible (LEL) Sensor <i>(catalytic bead)</i>

14 Appendix- Specifications

Sampling System	Diffusion
Detection Range	dependent on sensor
Housing	Metal or Polymeric conduit
Weight	3.7lbs [1.7Kg]

Electrical Specifications

Power Requirement	Class 2, 24 Vdc, nominal, 125 mA
Voltage	12-30 Volts DC
Current Maximum.....	300mA, typical 125mA
Termination Resistance	< 500 (250 recommended)
Grounding	Conduit must be earth grounded via conduit
Transmission Link	4–20 mA current, non-isolated 3 wires

Classification/Certification

Refer to Unit Mounted Label

NEC/CEC	CL 1, DIV 1, GPS B, C, D, T4
.....	CL 1, DIV 2, GPS B, C, D, T6
.....	CL 1, Zone 1 AEx db IIC T4 Gb
.....	CL 1, Zone 2 AEx ec nC IIC T6 Gc
ATEX	II 2 G Ex db IIC T4 Gb
.....	II 3 G Ex ec nC IIC T6 Gc
IECEX/CEC	Ex db IIC T4 Gb
.....	Ex ec nC IIC T6 Gc

Environment

Storage Temperature Range	-40°C to +50°C
Operating Humidity Range	0 – 95% RH, Non-condensing

- ⚠ To minimize static charge on Polymeric enclosure do not place unit in an air stream
- ⚠ This equipment includes some external non-metallic parts, including the outer protective coating. The user shall therefore ensure that the equipment is not installed in a location where it may be subjected to external conditions (such as high-pressure steam) which might cause a build-up of electrostatic charges on non-conducting surfaces. Additionally, cleaning of the equipment should be done only with a damp cloth

Note: Electromagnetic interference (EMI) signals may cause incorrect operation.

15 Appendix- Declaration of Conformity



EU DECLARATION OF CONFORMITY

Sensidyne, LP
1000 112th Circle North, Suite 100
St. Petersburg, Florida 33716

Certificate No: 001

Issue: 1

January 4, 2019

The undersigned declares that the products named in this certificate meet the provisions of the relevant Union harmonization legislation: EMC Directive 2014/30/EU for Electromagnetic Compatibility, RoHS Directive 2011/65/ EU for Restriction of Hazardous Substances in electrical equipment (category 11), Directive 2014/34/EU concerning equipment and protective systems intended for use in potentially explosive atmospheres and US and Canadian Hazardous Location and Electrical Equipment Requirements. This declaration is issued in the sole responsibility of Sensidyne, LP.

Product Type:	Gas Detection Equipment	
Product designation:	SensAir Toxic, Oxygen SensAir Combustible	(see below for model types) (see below for model types) (ATEX and IECEx Only)
Manufacturer:	Sensidyne, LP	
Intended Use:	Gas Detection	Notified Body(s):
Quality Assessment Report:	DIV 1 : GB/SrR/Q4R08.0026/05 DIV 2 : GB/SIR/QAR08.0026/06	Sira / CSA Group- Unit 6,Hawarden Industrial Park, Harwarden, CH5 3US, United Kingdom CSA Group – 178 Rexdale Blvd, Toronto, ON Canada M9W 1R3

DIVISION 1

US and Canada

Report No. : 70062157

SensAir Toxic/Oxygen Gas Detector, Model 820 series; input rated 24Vdc, 300mA. Ambient Temperature Range –20°C to +50°C. Rated Outputs: 4 - 20 mA.

Toxic/Oxygen Model Number:

820-XXXX-XXXX-R

820- a b- c d e f -R

a= 08 (Aluminum) or 16 (SS);

b= 01 thru 99 (Oxygen and varying toxic gases, as listed in the instruction manual)

c= 1 (display) or 2 (no display);

d= 0 (no options), 1 (MODBUS/Relay), 2 (BacNet), 3 (other) – does not affect certification;

e= 1 (horizontal) or 2 (vertical);

f= 2 (SS Sensor Holder with sintered disk), 3 (AI Sensor Holder with sintered disk);

CLASS 4828 02

Class I, Division 1, Groups B, C and D T4

Ex db IIC T4 Gb

CLASS 4828 82

Class I, Division 1, Groups B, C and D T4

Class I, Zone 1, AEx db IIC T4 Gb

Standards:

C22.2 No. 0-10(R2015)

CAN/CSA-C22.2 No. 60079-0:15

FM 3810 – 2017

FM 3615 – 2006

ANSI/UL-60079-1-2015

C22.2 No. 30-M1986 (R2016)

CAN/CSA-C22.2 No. 60079-1:16

FM 3600 – 2011

ANSI/ISA 60079-0 (12.00.01)-2013

	IECEX	ATEX Directive 2014/34/EU
Certificate number:	IECEX SIR 17.0008X	Sira 17ATEX1019X
Markings:	Ex db IIC T4 Gb	Ex db IIC T4 Gb
Report Number:	GB/SIR/ExTR18 0060/00	R70062156A
Standards:	IEC 60079-0:2011 Ed. 6 IEC 60079-1:2014 Ed. 7	EN 60079-0:2012/A11:2013 EN 60079-1:2014
SensAir Gas Detector Combustible; input rated 24Vdc, 500mA. Ambient range: –40°C to +75°C		
SensAir Gas Detector Toxic/Oxygen; input rated 24Vdc, 300mA. Ambient range: –20°C to +50°C		



DIVISION 2	
US and Canada	Certificate No. : 70182158
SensAir Toxic Gas Detector Standards: CAN/CSA-C22.2 No. 61010-1-12 UL Std. 61010-1 (3rd Edition) CSA-C22.2 No. 0-10 CAN/CSA-C22.2 No. 60079-0:15 CAN/CSA-C22.2 No. 60079-7:16 CAN/CSA-C22.2 No. 60079-15:16 C22.2 No. 213-17 UL 60079-0:2013, 6th Edition UL 60079-7:2017, 5th Edition UL 60079-15:2013, 4th Edition UL 121201 Ninth Edition	
Markings: Class I, Division 2, Groups B,C, and D, T6 Ex ec nC IIC T6 Gc Class I, Zone 2 AEx ec nC IIC T6 Gc	The model nomenclature is 820-aabb-cdef-R, where: aa = 09 (Aluminium Enclosure), 17 (Stainless Steel Enclosure) bb = 01 to 99 (Toxic Gas Options) c = 1 (with display), 2 (without display) d – Options that do not affect the hazardous locations marking e – Options that do not affect the hazardous locations marking f – Options that do not affect the hazardous locations marking
ATEX Directive 2014/34/EU	Certificate No. : Sira 18ATEX3276X
Standards: EN 60079-0:2018 EN 60079-7:2015/A1:2018 IEC 60079-15:2017	Markings: II 3G Ex ec nC IIC T6 Gc Ta Combustible Version = -40°C ≤ TA ≤ 55°C Ta Toxic Version = -20°C ≤ TA ≤ 50°C
IECEx	Certificate No. : IECEx CSA 18.0032X
Standards: IEC 60079-0 : 2017 Edition:7.0 IEC 60079-15 : 2017 Edition:5.0 IEC 60079-7 : 2017 Edition:5.1	Markings: Ex ec nC IIC T6 Gc Combustible Version: 24VDC, 500mA, -40°C ≤ TA ≤ 55°C Toxic Version: 24VDC, 300mA, -20°C ≤ TA ≤ 50°C
RoHS Directive 2011/65/EU Technical documentation on file for the assessment of electrical and electronic products with respect to the restriction of hazardous substances.	
EMI Verification Report Number Toxic 14F162C Oxygen 14F163C Combustible 14F187C	EMC Directive 2014/30/EU Report Number Toxic 14F162I Oxygen 14F163I Combustible 14F187I
Standards: EN 50270:2006 EN 61000-6-4:2007 ICES-003, CLASS A FCC PART 15 (per ANSI C63.4), CLASS A Verification EN 61000-6-4:2007	Standards: EN 50270: 2006 IEC 61000-4-2:2008 / EN 61000-4-2:2009 IEC 61000-4-3:2006 / EN 61000-4-3:2006 IEC 61000-4-4:2004 / EN 61000-4-4:2004 IEC 61000-4-5:2005 / EN 61000-4-5:2006 IEC 61000-4-6:2008 / EN 61000-4-6:2009 IEC 61000-4-8:2009 / EN 61000-4-8:2010

Signed:

Date:

Name: Aaron Clem

Title: Manager: Quality Assurance /Regulatory Affairs Sensidyne, LP



16 Appendix- Allowable Line Lengths

Class 2 Power Supply Voltage (Vdc)	4-20mA Termination (Ohms)	Allowable Loop Resistance (Ohms)	Wire Gauge	Allowable Line Length (Feet)	Allowable Line Length (Meters)
30	250	110	14	27,000	8,200
			16	17,000	5,150
			18	10,600	3,250
			20	6,050	1,800
			24	4,200	1,250
28	250	95	14	23,400	7,100
			16	14,700	4,450
			18	9,200	2,800
			20	5,200	1,550
			24	2,300	700
26	250	80	14	19,800	6,000
			16	12,400	3,800
			18	7,800	2,350
			20	4,400	1,350
			24	1,950	550
24	250	65	14	16,200	4,900
			16	10,200	3,100
			18	6,350	1,950
			20	3,600	1,100
			24	1,600	490
22	250	58	14	12,600	3,800
			16	7,900	2,400
			18	4,950	1,500
			20	2,800	850
			24	1,250	380
20	250	51	14	9,000	2,700
			16	5,650	1,700
			18	3,550	1,050
			20	2,000	600
			24	850	270
18	250	20	14	5,400	1,600
			16	3,400	1,000
			18	2,100	650
			20	1,200	360
			24	500	160
16	250	14	14	1,800	500
			16	1,100	340
			18	700	210
			20	400	120
			24	170	50

17 Optional Communication / Relay Board

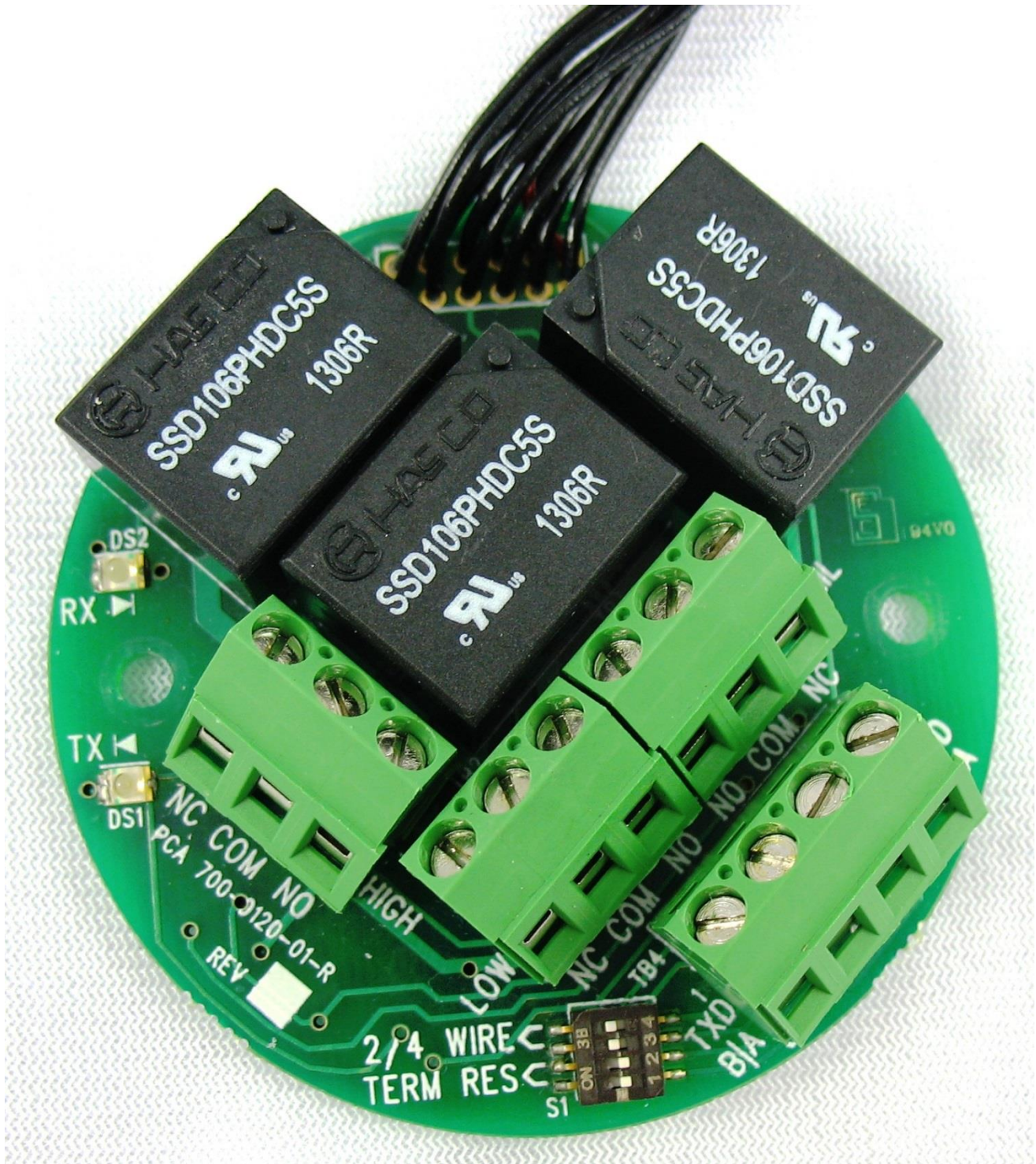

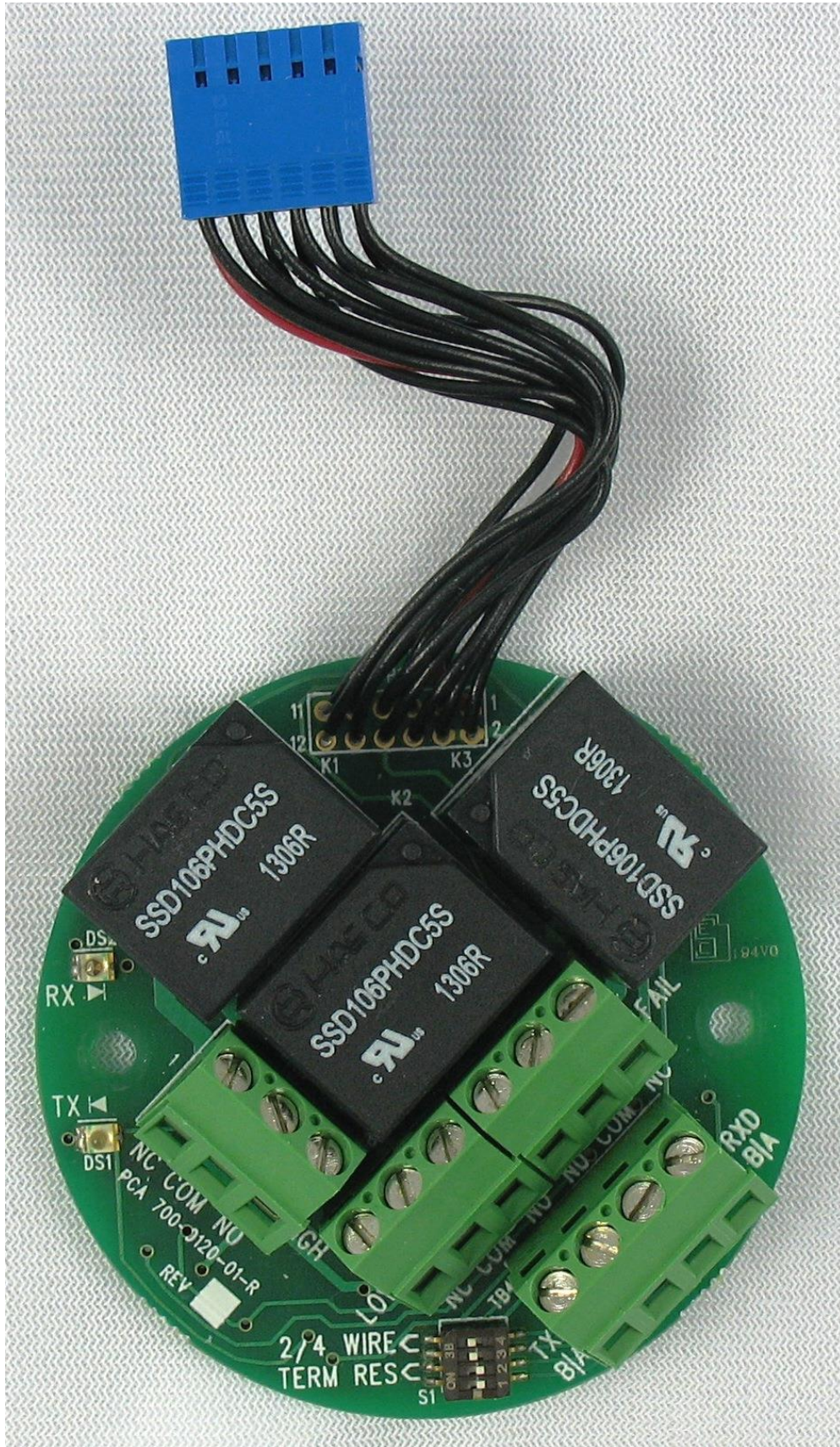

SensAir Toxic Gas Detector

Remove factory supplied test wires. In order to maintain RF immunity move all ferrites from test wires to user supplied wiring

4 wire connections and termination resistors

SensAir	Test Lead Color	Modbus Master
TB4-1 TXD-B	Gray	RXD-A
TB4-2 TXD-A	Violet	RXD-B
TB4-3 RXD-B	Green	TXD-A
TB4-4 RXD-A	Brown	TXD-B

No termination resistors:

S1-1	Off
S1-2	Off
S1-3	Off
S1-4	Off

With termination resistors

S1-1	On
S1-2	On
S1-3	Off
S1-4	Off

2 wire connections and termination resistors

SensAir	Test Lead Color	Modbus Master
TB4-1 TXD-B	Gray	A
TB4-2 TXD-A	Violet	B
TB4-3 RXD-B	Not Used	Not Used
TB4-4 RXD-A	Not Used	Not Used

No termination resistors:

S1-1	Off
S1-2	Off
S1-3	On
S1-4	On

With termination resistors:

S1-1	On
S1-2	Off
S1-3	On
S1-4	On

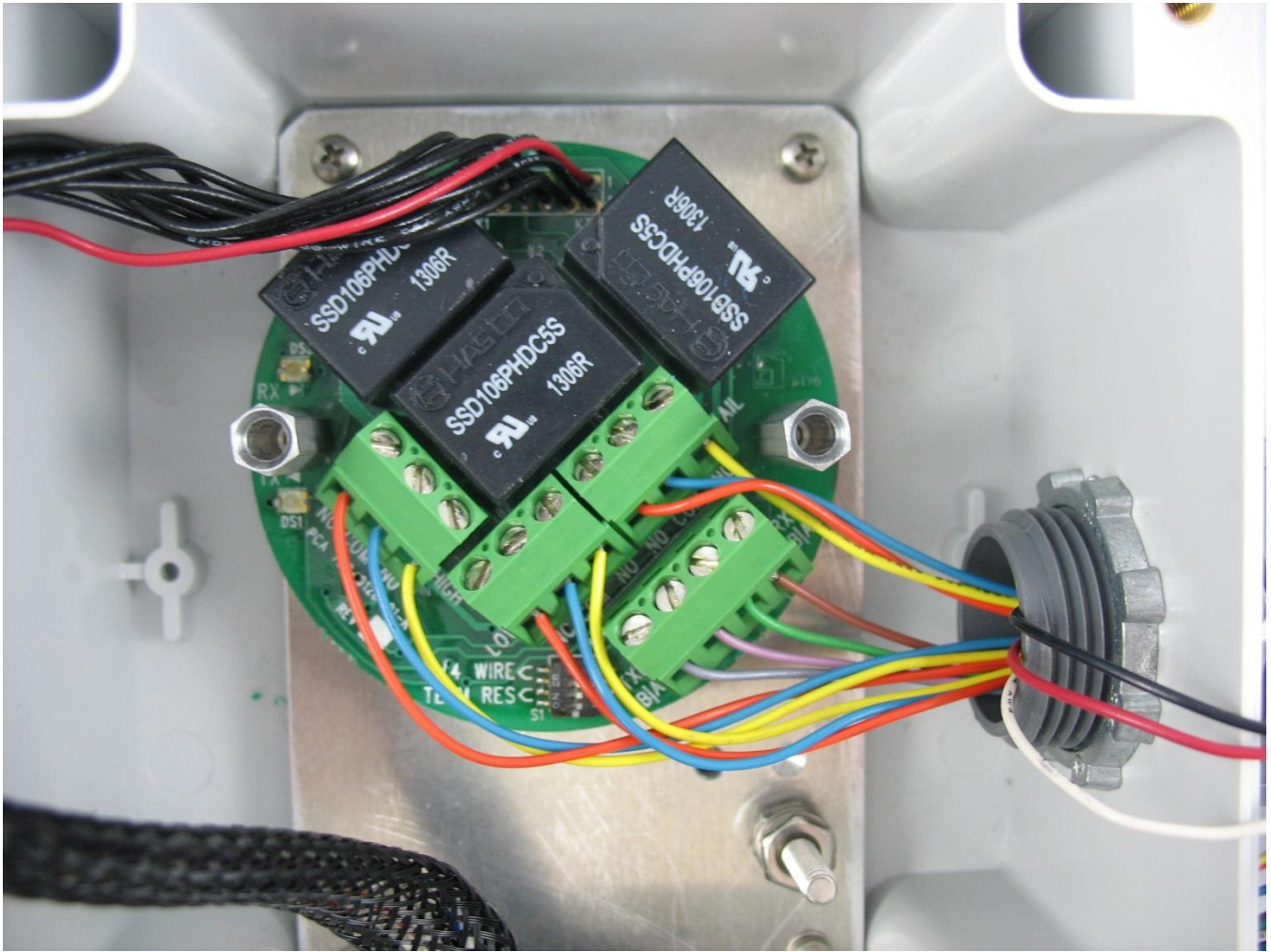

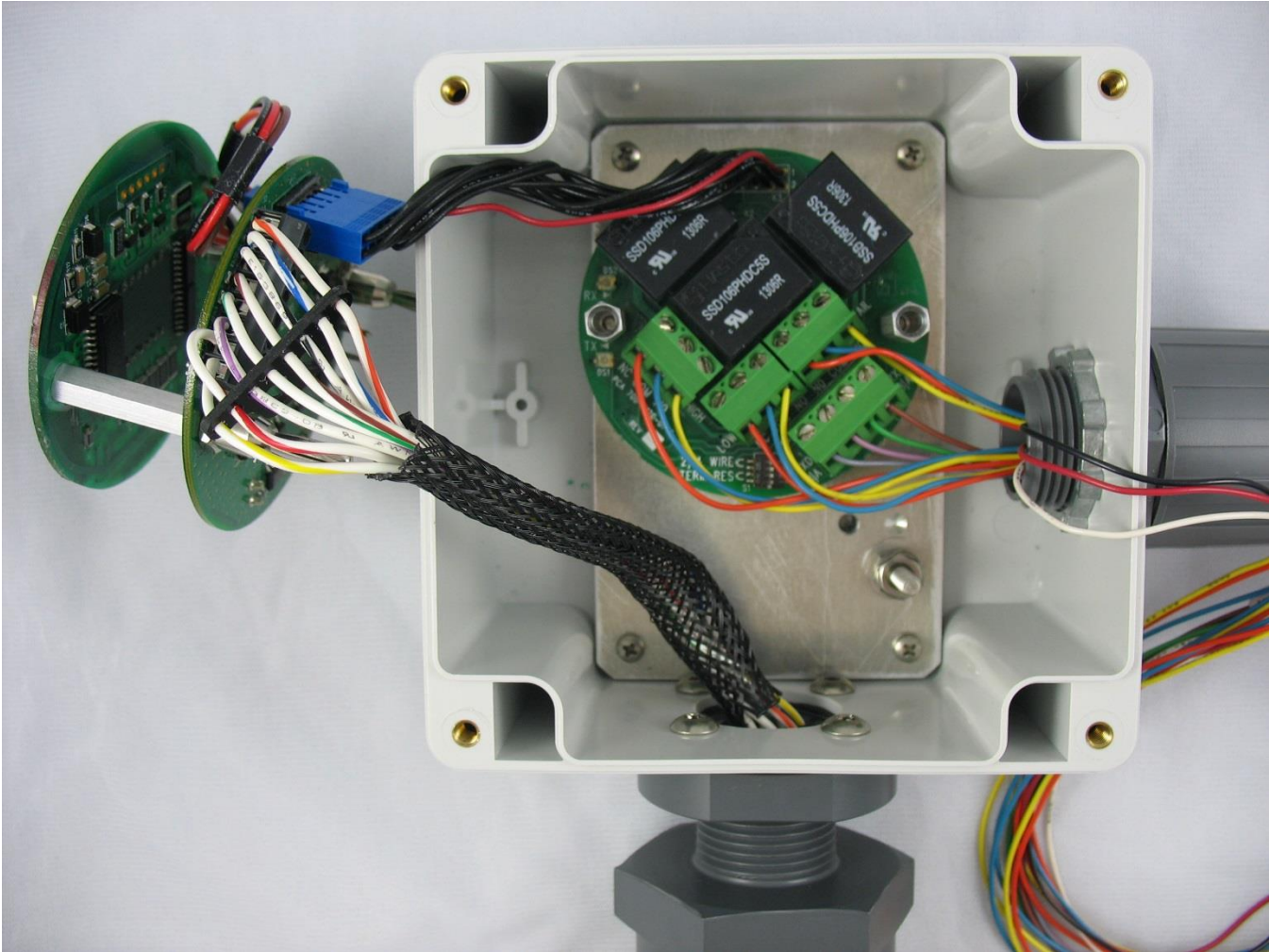

18 SensAir Modbus Register Addresses (option)

If Modbus Option Board is present.

Coils

00001	Start Zero
00002	Start Calibration
00003	Clear Latched Relays
00004	Low Latch Enable
00005	High Latch Enable
00006	Enable Current Monitor

Discrete Inputs

10002	Zeroing Sensor Good
10003	Zeroing Sensor Failed
10004	Calibration of Sensor Good
10005	Calibration of Sensor Failed
10006	Fail Active
10007	Low Active
10008	High Active
10009	Fail Latched
10010	Low Latched
10011	High Latched
10012	Sensor Fail Active
10013	Sensor Missing Active
10014	Loop Current Out of Tolerance
10015	Calibration Mode Fault Active
10016	Zero Mode Active
10017	Maintenance Mode Fault Active

Input Registers

30031	Float	Gas Concentration
30033	Float	Full Scale Value
30035	Float	Loop Current in mA
30037	Int	12 Bit Representation of Current Loop, 4mA is a count of 800, 20mA is a count of 4000

Holding Registers

40127	Float	Low Alarm Setpoint
40129	Float	High Alarm Setpoint

19 SensAir Modbus Specifications (option)

Modbus Specifications

RTU Transmission Mode

Byte-order: most-significant-first

Functions 01 (0x01) Read Coils

02 (0x02) Read Discrete Inputs

03 (0x03) Read Holding Registers

04 (0x04) Read Input Registers

05 (0x05) Write Single Coil

06 (0x06) Write Single Register

• Modbus RS485 Electrical Specifications

RS485 2 wire or 4 wire

Termination Resistors 120Ω ohms

RS485 Load 2 wire – ½ Load

4 wire – ¼ Load

• Comm Port Specifications

Baud Rate 9600, 19200, 38400

Parity None

Start Bit 1

Data Bits 8

Stop Bit 1

• Indicators

RX LED Indicates received communications

TX LED Indicates transmitted communications

• Cable Recommendations

20-24 AWG Twisted Pair, Overall Shielded

2 wire – Single Pair

4 wire – Two Pair

Belden 9501, 9502, 8451, 8761, 1419A

Alpha Wire 5471C, 5472C

20 SensAir BACnet Specifications (option)

If BACnet Option Board is present.

This specification defines the implementation of BACnet (ANSI/ASHRAE 135-2012) for the SensAir product line.

The BACnet interface implements the following features:

- 1) Gas name and detection concentration limits
- 2) Current gas concentration value
 - a. O₂ : % Volume
 - b. Combustible : % LEL (Lower Explosive Limit)
 - c. Toxic: ppm (Parts Per Million)
- 3) Device Object Identifier (network device ID number), editable by user
- 4) Device Object Name, editable by user
- 5) Device Location, editable by user
- 6) Selectable Baud rate (9600, 19200, 38400, 57600)
- 7) Alarm set-points can be read and written
- 8) Alarms can be latched, regardless of the presence of relays.
- 9) The zeroing function can be activated remotely if the reading is below 3% of full scale. Feature not available on O₂ sensor.
- 10) Missing sensor and sensor fail status can be read (implemented using Reliability property of the Gas_Concentration object).
- 11) Indication that the unit is being serviced (implemented using Out_Of_Service property)
- 12) Some objects implement “dummy” values while OutOfService is active, to facilitate testing of BACnet user interface.

Hardware Interface and BACnet settings arbitration

Any value, setting or property that can be changed through either the hardware device, or through BACnet, will assume the value most recently set.

Data Link Layer:

Data Link Layer Implementation: MS/TP Master

Physical Layer:

Physical Layer Implementation: RS-485 2-wire and 4-wire

Supported BAUD rates: 9600, 19200, 38400, 57600.

Configurable via LED display and magnetic switches. Not configurable through BACnet interface.

Default MAC Address: 127

Configurable via LED display and magnetic switches. Not configurable through BACnet interface.

BACnet Standardized Device Profile:

This device implements a **BACnet Smart Sensor (B-SS)** profile.

BACnet Interoperability Building Blocks Supported (Annex K):		
BIBB	Service	Example
DS-RP-B	Read Property	Analog Input Services
DS-WP-B	Write Property	Binary Value Services
DM-DDB-B	Device Management-Dynamic Device Binding	Who-Is, I-Am services
DM-DOB-B	Device Management-Dynamic Object Binding	Who-Has, I-Have services
NOT SUPPORTED: DM-DCC-B	Device Management-DeviceCommunicationControl	Temporarily silence communication

* Alarm and Event Notification is not supported.

BACnet Objects and Descriptions

BACnet Objects Overview				
Object Type	Dynamically Creatable	Dynamically Deletable	Object Identifier	Object Name
Device	No	No	766xxx	See Error! Reference source not found.
Analog Input	No	No	AI 1	Gas Concentration
Analog Value	No	No	AV 1	Gas Alarm Setpoint High ¹
			AV 2	Gas Alarm Setpoint Low
Binary Value	No	No	BV 1	Zeroing Active
			BV 2	Calibrating Active
			BV 3	High Alarm Active ²
			BV 4	Low Alarm Active
			BV 5	High Alarm Latch Mode Enabled ³
			BV 6	Low Alarm Latch Mode Enabled
			BV 7	High Alarm Latched ⁴
			BV 8	Low Alarm Latched

- 1) Only for O2 sensor, Object_Name is **Gas Alarm Setpoint Low Low** and is the most-urgent setpoint
- 2) Only for O2 sensor, Object_Name is **Low Low Alarm Active** and is the most-urgent alarm
- 3) Only for O2 sensor, Object_Name is **Low Low Alarm Latch Mode Enabled** and corresponds to the most-urgent alarm.
- 4) Only for O2 sensor, Object_Name is **Low Low Latched** and corresponds to the most-urgent alarm

Table Keys		
Storage Type	C	Property is hard-coded as a constant
	N	Property is stored in non-volatile memory
	R	Property is computed constantly and stored in RAM
Required	R	Property is required by ASHRAE Standard 135
	O	Property is optional in ASHRAE Standard 135

BACnet Device Object					
Property	Default Value	Data Type	Access	Storage	Required
Object Identifier	Device, 766xxx	BACnetObjectIdentifier	Read	N	R
Object Type	device (8)	BACnetObjectType	Read	C	R
Vendor Identifier	Sensidyne (766)	Unsigned16	Read	C	R
Vendor Name	"Sensidyne, LP"	CharacterString	Read	C	R
Location	"default location"	CharacterString	Read / Write	N	O
Object Name	See Error! eference source not found.	CharacterString	Read / Write	N	R
Model Name	See Error! eference source not found.	CharacterString	Read	C	R
Description	See Error! eference source not found.	CharacterString	Read	C	O
Firmware Revision	"0.8.3"	CharacterString	Read	C	R
Application Software Version	"1.1"	CharacterString	Read	C	R
Protocol Object Types Supported	"analog_input, analog_value, binary_value, device"	BACnetObjectTypesSupported	Read	C	R
Protocol Services Supported	"readProperty, writeProperty, who_ls,"	BACnetServicesSupported	Read	C	R
Protocol Version	1	Unsigned	Read	C	R
Protocol Revision	14	Unsigned	Read	C	R
Database Revision	1	Unsigned	Read	C	R
System Status	OPERATIONAL (0)	BACnetDeviceStatus	Read	R	R
Max Adu Length Accepted	50	Unsigned	Read	C	R
Max Info Frames	1	Unsigned	Read	C	O
Max Master	127	Unsigned	Read	C	O
Adu Timeout	3000	Unsigned	Read	C	R
Number Of Adu Retries	3	Unsigned	Read	C	R
Device_Address_Binding	{}	BACnetLIST of BACnetAddressBinding	Read	C	R
Segmentation Supported	No Segmentation (3)	BACnetSegmentation	Read	C	R
Object_List	List of BACnet objects implemented in this device	Array of BACnetObjectIdentifier	Read	C	R
Property_List	List of supported properties	Array of BACnetPropertyIdentifier	Read	C	R

Object Identifier is the BACnet Device Instance number. It is created by the concatenation of the Sensidyne Vendor ID number (766) and the Device Address, which is configurable on the physical device's menu, using the LED display and the magnetic switches. The maximum address is equal to Max_Master, so the valid range of the Device Address is 1-127, where 127 is the default. Therefore, the valid range of Device Instance Numbers is 766001 through 766127.

SensAir Toxic Gas Detector

Object_Name and Location properties are user-configurable. Default values are shown in the tables. Maximum length for this text is 43 characters each.			
Product Name	Object_Name (default)	Model_Name	Description
Oxygen 25	SensAir Oxygen 25	820-xx01-x2xx-R	SensAir sensor for Oxygen (O2) gas
H2S 50	SensAir H2S 50	820-xx02-x2xx-R	SensAir for Hydrogen Sulfide (H2S)
H2S 100	SensAir H2S 100	820-xx03-x2xx-R	Sensidyne SensAir sensor for (H2S) gas
NH3 50	SensAir NH3 50	820-xx04-x2xx-R	Sensidyne SensAir sensor for Ammonia (NH3)
NH3 100	SensAir NH3 100	820-xx05-x2xx-R	Sensidyne SensAir sensor for Ammonia (NH3)
NH3 300	SensAir NH3 300	820-xx06-x2xx-R	Sensidyne SensAir sensor for Ammonia (NH3)
CO 100	SensAir CO 100	820-xx07-x2xx-R	SensAir sensor for Carbon Monoxide (CO) gas
CO 500	SensAir CO 500	820-xx08-x2xx-R	SensAir sensor for Carbon Monoxide (CO) gas
CO 1000	SensAir CO 1000	820-xx09-x2xx-R	SensAir sensor for Carbon Monoxide (CO) gas
Cl2 5	SensAir Cl2 5	820-xx10-x2xx-R	SensAir sensor for Chlorine (Cl2) gas
Cl2 10	SensAir Cl2 10	820-xx11-x2xx-R	SensAir sensor for Chlorine (Cl2) gas
HCl 10	SensAir HCl 10	820-xx12-x2xx-R	SensAir sensor for Hydrogen Chloride (HCl)
HCl 100	SensAir HCl 100	820-xx13-x2xx-R	SensAir sensor for Hydrogen Chloride (HCl)
NO2 10	SensAir NO2 10	820-xx14-x2xx-R	SensAir sensor for Nitrogen Dioxide (NO2)
H2 1000	SensAir H2 1000	820-xx15-x2xx-R	Sensidyne SensAir sensor for Hydrogen (H2)
HCN 20	SensAir HCN 20	820-xx16-x2xx-R	SensAir sensor for Hydrogen Cyanide (HCN)
HF 10	SensAir HF 10	820-xx17-x2xx-R	SensAir sensor for Hydrogen Fluoride (HF)
SO2 20	SensAir SO2 20	820-xx18-x2xx-R	SensAir sensor for Sulfur Dioxide (SO2)
ClO2 5	SensAir ClO2 5	820-xx19-x2xx-R	SensAir sensor for Chlorine Dioxide (ClO2)
Combustible LEL 100	SensAir Comb LEL 100	820-0600-02-R	SensAir sensor for combustible gas

Gas Concentration					
Property	Default Value	Data Type	Access	Storage	Required
Object_Identifier	A11 (Analog Input 1)	BACnetObjectIdentifier	Read	C	R
Object_Name	"Gas Concentration"	CharacterString	Read	C	R
Object_Type	Analog_Input (0)	BACnetObjectType	Read	C	R
Description	See Error! Reference source not found.	CharacterString	Read	C	O
Device_Type	See Error! Reference source not found.	CharacterString	Read	C	O
Present_Value	Current Reading	REAL	Read*	R	R
Resolution	See Error! Reference source not found.	REAL	Read	C	O
Min_Pres_Value	0.0	REAL	Read	C	O
Max_Pres_Value	110% of Full Scale (See Error! Reference source not found.)	REAL	Read	C	O
Units	See Error! Reference source not found.	BACnetEngineeringUnits	Read	C	R
Out_Of_Service	FALSE (0)	BOOLEAN	Read / Write	R	R
Status_Flags	All False (0,0,0,0)	BACnetStatusFlags	Read	R	R
Event_State	NORMAL (0)	BACnetEventState	Read	R	R
Reliability	NO_FAULT_DETECTED (0)	BACnetReliability	Read	R	O
Property_List	List of supported properties	Array of BACnetPropertyIdentifier	Read	C	R

Table 1

Marketing Product Name	Description	Device Type	Units	Full-Scale	Resolution
Oxygen 25	Oxygen Concentration Percent Volume	0-25% O2 Sensor	Percent (98)	25.0%	0.1%
H2S 50	Hydrogen Sulfide Concentration ppm	0 – 50 ppm H2S Sensor	PPM (96)	50	1
H2S 100	Hydrogen Sulfide Concentration ppm	0 – 100 ppm H2S Sensor	PPM (96)	100	1
NH3 50	Ammonia Concentration Parts Per Million	0 – 50 ppm NH3 Sensor	PPM (96)	50	1
NH3 100	Ammonia Concentration Parts Per Million	0 – 100 ppm NH3 Sensor	PPM (96)	100	1
NH3 300	Ammonia Concentration Parts Per Million	0 – 300 ppm NH3 Sensor	PPM (96)	300	1
CO 100	Carbon Monoxide Concentration ppm	0 – 100 ppm CO Sensor	PPM (96)	100	1
CO 500	Carbon Monoxide Concentration ppm	0 – 500 ppm CO Sensor	PPM (96)	500	1
CO 1000	Carbon Monoxide Concentration ppm	0 – 1000 ppm CO Sensor	PPM (96)	1000	1
Cl2 5	Chlorine Concentration Parts Per Million	0 – 5 ppm Cl2 Sensor	PPM (96)	5.0	0.1
Cl2 10	Chlorine Concentration Parts Per Million	0 – 10 ppm Cl2 Sensor	PPM (96)	10.0	0.1
HCl 10	Hydrogen Chloride Concentration ppm	0 – 10 ppm HCl Sensor	PPM (96)	10.0	0.1
HCl 100	Hydrogen Chloride Concentration ppm	0 – 100 ppm HCl Sensor	PPM (96)	100	1
NO2 10	Nitric Oxide Concentration ppm	0 – 10 ppm NO2 Sensor	PPM (96)	10.0	0.1
H2 1000	Hydrogen Concentration Parts Per Million	0 – 1000 ppm H2 Sensor	PPM (96)	1000	1
HCN 20	Hydrogen Cyanide Concentration ppm	0 – 20 ppm HCN Sensor	PPM (96)	20.0	0.1
HF 10	Hydrogen Fluoride Concentration ppm	0 – 10 ppm NO2 Sensor	PPM (96)	10.0	0.1
SO2 20	Sulfur Dioxide Concentration ppm	0 – 20 ppm NO2 Sensor	PPM (96)	20.0	0.1
ClO2 5	Chlorine Dioxide Concentration ppm	0 – 5 ppm ClO2 Sensor	PPM (96)	5.00	0.01
Combustible	Concentration Percent LEL	0 – 100 %LEL Sensor	Percent (98)	100	1

Present Value Property

The gas concentration measurement value that is used internally, displayed on the device LED display, and used for activating alarms, cannot be altered.

When `OutOfService` is enabled (`OutOfService = TRUE`), a dummy value is used for `PresentValue`, which can be written and read through the BACnet network. This facilitates network integration and testing of the BAC controller and display device.

When `OutOfService` is changed from disabled to enabled, the current (real) `PresentValue` is copied to the dummy value, but the dummy value is not subsequently updated.

Writing and reading `PresentValue` while `OutOfService` is active will alter and return this dummy value, but has no effect on the measurement value used internally. This dummy value is not used for activating alarms. Therefore, writing a value that is beyond an Alarm Setpoint will not cause the alarm to activate. The value read and written is not constrained to valid values, so invalid values may be written.

If the value written to `PresentValue` is invalid, the following actions will occur:

- `PresentValue` will be set to the entered value, rounded to the available resolution of the sensor.
- An error response “(property) Value Out of Range” will be returned.
- The Reliability property will be set to indicate the error status (see below).

Reliability Property

The Reliability property will be altered as a result of problems detected with the gas sensor, or by an unusual status of the Zeroing_Active or Calibrating_Active objects.

- NO_FAULT_DETECTED (0) indicates the device is operating normally.
- NO_SENSOR (1) indicates that an error has been detected with the gas sensor. The user should perform a diagnostic test on the sensor.
- PROCESS_ERROR (8) indicates that one of the Zeroing_Active or Calibrating_Active objects has an unusual status. The user should investigate the situation and retry the zeroing or calibration process as necessary.
- RELIABILITY_NO_OUTPUT (6) indicates that either the device is in “Maintenance Mode”, or Zeroing or Calibrating processes are in-progress. The corresponding BinaryValue object (Zeroing_Active or Calibrating_Active) will have a value of Active (1).

Note: These processes may have been initiated at the device, not through BACnet.

Note: Maintenance Mode is not a BACnet property. It is initiated by a technician through the faceplate on the device.

- OVER_RANGE (2) indicates the Present_Value was set higher than the permissible range (while OutOfService is active).
- UNDER_RANGE (3) will be returned during “warm-up”, which lasts for 60 seconds after the device is powered on. Otherwise it indicates the Present_Value was set lower than the permissible range (while OutOfService is active).

If multiple conditions exist that affect the Reliability property, the most severe condition will be indicated. In descending order of severity:

- 1) NO_SENSOR (most severe)
- 2) PROCESS_ERROR
- 3) OVER_RANGE
- 4) UNDER_RANGE
- 5) RELIABILITY_NO_OUTPUT
- 6) NO_FAULT_DETECTED

Gas Alarm High / Gas Alarm Low-Low					
Property	Default Value	Data Type	Access	Storage	Required
Object_Identifier	AV1 (Analog Value 1)	BACnetObjectIdentifier	Read	N	R
Object_Name	"Gas Alarm Setpoint High"	CharacterString	Read	C	R
Object_Type	Analog_Value (2)	BACnetObjectType	Read	C	R
Description	See Table 2	CharacterString	Read	C	O
Present_Value	Current Reading	REAL	Read / Write	R	R
Units	Same as AI1 (See Error! Reference source not found.)	BACnetEngineeringUnits	Read	C	R
Min_Pres_Value	10% of Full Scale (See Error! Reference source not found.)	REAL	Read	C	O
Max_Pres_Value	60% of Full Scale (See Error! Reference source not found.)	REAL	Read	C	O
Resolution	See Error! Reference source not found.	REAL	REAL	C	O
Out_Of_Service	FALSE (0)	BOOLEAN	Read / Write	R	R
Status_Flags	All False (0,0,0,0)	BACnetStatusFlags	Read	R	R
Event_State	NORMAL (0)	BACnetEventState	Read	R	R
Reliability	NO_FAULT_DETECTED (0)	BACnetReliability	Read	R	O
Property_List	List of supported properties	Array of BACnetPropertyIdentifier	Read	C	R

* For O₂ sensor only, Object_Name is Gas_Alarm_Setpoint_Low_Low and is the most-urgent alarm setpoint

Table 2

Version-Specific Device Properties		
Marketing Product Name	Object_Name	Description
O2 25	Gas Alarm Setpoint Low Low	Setpoint Low-Low Alarm
H2S 50	Gas Alarm Setpoint High	Setpoint High Alarm
H2S 100	Gas Alarm Setpoint High	Setpoint High Alarm
NH3 50	Gas Alarm Setpoint High	Setpoint High Alarm
NH3 100	Gas Alarm Setpoint High	Setpoint High Alarm
NH3 300	Gas Alarm Setpoint High	Setpoint High Alarm
CO 100	Gas Alarm Setpoint High	Setpoint High Alarm
CO 500	Gas Alarm Setpoint High	Setpoint High Alarm
CO 1000	Gas Alarm Setpoint High	Setpoint High Alarm
Cl2 5	Gas Alarm Setpoint High	Setpoint High Alarm
Cl2 10	Gas Alarm Setpoint High	Setpoint High Alarm
HCl 10	Gas Alarm Setpoint High	Setpoint High Alarm
HCl 100	Gas Alarm Setpoint High	Setpoint High Alarm
NO2 10	Gas Alarm Setpoint High	Setpoint High Alarm
H2 1000	Gas Alarm Setpoint High	Setpoint High Alarm
HCN 20	Gas Alarm Setpoint High	Setpoint High Alarm
HF 10	Gas Alarm Setpoint High	Setpoint High Alarm
SO2 20	Gas Alarm Setpoint High	Setpoint High Alarm
ClO2 5	Gas Alarm Setpoint High	Setpoint High Alarm
Combustible	Gas Alarm Setpoint High	Setpoint High Alarm

Summary

Analog Value 1 is the "more severe" alarm. For toxic and combustible gases, this is the higher-concentration setpoint. For breathable oxygen (O₂), this is the lower-concentration setpoint.

Present Value Property

Analog Value 1 must be higher than, or equal to, Analog Value 2 for toxic and combustible gas sensors, and must be lower than, or equal to, Analog Value 2 for the O₂ sensor. If the Present Value is set too high or too low, it will be constrained and set to the highest or lowest (respectively) value allowed, and will return the response ERROR_CODE_VALUE_OUT_OF_RANGE(37).

A dummy value is used for PresentValue while OutOfService is TRUE. Writing and reading to PresentValue while OutOfService is active will alter and return this dummy, but has no effect on the value used internally for the alarm set points.

When OutOfService is disabled, the real setpoint values can be read and written.

Refer to Table 1 to determine the maximum and minimum values and decimal precision for each sensor type.

If the value written to PresentValue is invalid, the following actions will occur:

- PresentValue will be set to the closest valid value. For example, if the value entered is too large, PresentValue will be set to the maximum valid value.
- An error response “(property) Value Out of Range” will be returned.

Reliability Property

NO_FAULT_DETECTED (0) indicates the Present_Value is valid.

Gas Alarm Low					
Property	Default Value	Data Type	Access	Storage	Required
Object_Identifier	AV2 (Analog Value 2)	BACnetObjectIdentifier	Read	C	R
Object_Name	“Gas Alarm Setpoint Low”	CharacterString	Read	C	R
Object_Type	Analog_Value (2)	BACnetObjectType	Read	C	R
Description	See Table 4	CharacterString	Read	C	O
Present_Value	Current Reading	REAL	Read / Write	R	R
Units	Same as AI1 (See Error! eference source not found.)	BACnetEngineeringUnits	Read	C	R
Min_Pres_Value	10% of Full Scale (See Error! eference source not found.)	REAL	Read	C	O
Max_Pres_Value	60% of Full Scale (See Error! eference source not found.)	REAL	Read	C	O
Resolution	See Error! Reference ource not found.	REAL	REAL	C	O
Out_Of_Service	FALSE (0)	BOOLEAN	Read / Write	R	R
Status_Flags	All False (0,0,0,0)	BACnetStatusFlags	Read	R	R
Event_State	NORMAL (0)	BACnetEventState	Read	R	R
Reliability	NO_FAULT_DETECTED (0)	BACnetReliability	Read	R	O
Property_List	List of supported properties	Array of BACnetPropertyIdentifier	Read	C	R

Table 3

Version-Specific Device Properties	
Marketing Product Name	Description
O2 25	Setpoint Low Alarm
H2S 50	Setpoint Low Alarm
H2S 100	Setpoint Low Alarm
NH3 50	Setpoint Low Alarm
NH3 100	Setpoint Low Alarm
NH3 300	Setpoint Low Alarm
CO 100	Setpoint Low Alarm
CO 500	Setpoint Low Alarm
CO 1000	Setpoint Low Alarm
Cl2 5	Setpoint Low Alarm
Cl2 10	Setpoint Low Alarm
HCl 10	Setpoint Low Alarm
HCl 100	Setpoint Low Alarm
NO2 10	Setpoint Low Alarm
H2 1000	Setpoint Low Alarm
HCN 20	Setpoint Low Alarm
HF 10	Setpoint Low Alarm
SO2 20	Setpoint Low Alarm
ClO2 5	Setpoint Low Alarm
Combustible	Setpoint Low Alarm

Summary

Analog Value 2 is the “less severe” alarm. For toxic and combustible gases, this is the lower-concentration setpoint. For breathable oxygen (O₂), this is the higher-concentration setpoint.

Present Value Property

A dummy value is used while for PresentValue while OutOfService is TRUE. Writing and reading to PresentValue while OutOfService is active will alter and return this dummy, but has no effect on the value used internally for the alarm set points. When OutOfService is disabled, the real setpoint values can be read and written.

Refer to Table 1 to determine the maximum and minimum values and decimal precision for each sensor type.

If the value written to PresentValue is invalid, the following actions will occur:

- PresentValue will be set to the closest valid value. For example, if the value entered is too large, PresentValue will be set to the maximum valid value.
- An error response “(property) Value Out of Range” will be returned.

Reliability Property

NO_FAULT_DETECTED (0) indicates the Present_Value is valid.

Zeroing Active					
Property	Default Value	Data Type	Access	Storage	Required
Object_Identifier	BV1 (Binary Value 1)	BACnetObjectIdentifier	Read	C	R
Object_Name	"Zeroing Active"	CharacterString	Read	C	R
Description	"Set or Read Zeroing Status"	CharacterString	Read	C	O
Object_Type	Binary_Value (5)	BACnetObjectType	Read	C	R
Present_Value	INACTIVE (0)	BACnetBinaryPV (Boolean)	Read / Write	R	R
Out_Of_Service	FALSE (0)	BOOLEAN	Read	R	R
Status_Flags	All False (0,0,0,0)	BACnetStatusFlags	Read	R	R
Event_State	NORMAL (0)	BACnetEventState	Read	R	R
Reliability	NO_FAULT_DETECTED (0)	BACnetReliability	Read	R	O
Property_List	List of supported properties	Array of BACnetPropertyIdentifier	Read	C	R

Zeroing the sensor

Zero Calibration can be performed either on the physical device, using the LED display and magnetic switches, or via the BACnet interface.

Zeroing is not available for the Oxygen (O₂) sensor. If attempted, the BACnet interface will respond with the property error "Operational Problem" and the command will be ignored.

The zeroing function will take approximately one minute. After this time, the value of the Zeroing_Active object will return to INACTIVE (0).

If the current reading is 3% or higher, the zeroing function cannot run. In this case the following actions occur:

- 1) Present_Value is immediately set to INACTIVE (0)
- 2) The Reliability property of Zeroing_Active will be assigned the value OVER_RANGE (2).
- 3) The Reliability property of Gas_Concentration will be assigned the value PROCESS_ERROR (8) unless a more severe error code already exists.

Present Value

The Present_Value property can be used to initiate the zeroing function by writing a value of ACTIVE (1) to the Zeroing_Active object.

Present_Value will have a value of ACTIVE (1) only while the device is in the process of zeroing. A value of INACTIVE (0) indicates that the zeroing process is not active, either because it has not been started, completed successfully, failed, or was canceled by the user.

- ERROR_CODE_OPERATIONAL_PROBLEM (22) response indicates that the Zeroing function was aborted because the gas concentration value was 3% or higher.

Reliability

The Reliability property indicates the status of the most recent Zeroing operation.

- NO_FAULT_DETECTED (0) indicates the Zeroing function completed successfully, or has not been started since power-on.
- PROCESS_ERROR (8) indicates the Zeroing process failed, or was canceled by the user.
- In any case other than NO_FAULT_DETECTED, the Reliability property of the Gas_Concentration object will also be set to PROCESS_ERROR (8) to indicate an unusual status exists.

Out of Service

OUT_OF_SERVICE is not implemented in this object. Reading OUT_OF_SERVICE will always return FALSE(0). Writing to OUT_OF_SERVICE will return the status "(property) Write Access Denied".

Calibrating Active					
Property	Default Value	Data Type	Access	Storage	Required
Object_Identifier	BV2 (Binary Value 2)	BACnetObjectIdentifier	Read	C	R
Object_Name	"Calibrating Active"	CharacterString	Read	C	R
Description	"Read Calibrating Status"	CharacterString	Read	C	O
Object_Type	Binary_Value (5)	BACnetObjectType	Read	C	R
Present_Value	INACTIVE (0)	BACnetBinaryPV (Boolean)	Read	R	R
Out_Of_Service	FALSE (0)	BOOLEAN	Read	R	R
Status_Flags	All False (0,0,0,0)	BACnetStatusFlags	Read	R	R
Event_State	NORMAL (0)	BACnetEventState	Read	R	R
Reliability	NO_FAULT_DETECTED (0)	BACnetReliability	Read	R	O
Property_List	List of supported properties	Array of BACnetPropertyIdentifier	Read	C	R

Calibrating the sensor

Calibration can be performed only on the physical device, using the LED display and magnetic switches. Writing to the Calibrating_Active Present_Value will have no effect.

The BACnet interface can be used to monitor the status of calibration activity.

Present Value

The Present_Value property is read-only because calibration requires a technician to apply the calibration gas to the sensor and adjust the sensor using the faceplate. Therefore, it is not allowed to be initiated remotely. Reading Present_Value will return a value of ACTIVE (1) only while the device is in the process of calibration. A value of INACTIVE (0) indicates that the calibration process is not active, either because it has not been started, succeeded, failed, or was canceled by the user.

Reliability

The Reliability property indicates the status of the most recent Calibration operation.

- NO_FAULT_DETECTED (0) indicates the Calibration function completed successfully, or has not been started since power-on.
- PROCESS_ERROR (8) indicates the Calibration process failed, or was canceled by the user.
- In any case other than NO_FAULT_DETECTED, the Reliability property of the Gas_Concentration object will also be set to PROCESS_ERROR (8) to indicate an unusual status exists.

Out of Service

OUT_OF_SERVICE is not implemented in this object. Reading OUT_OF_SERVICE will always return FALSE(0).

High Alarm Active					
Property	Default Value	Data Type	Access	Storage	Required
Object_Identifier	BV3 (Binary Value 3)	BACnetObjectIdentifier	Read	C	R
Object_Name	"High Alarm Active"*	CharacterString	Read	C	R
Description	"Gas is in the High Alarm range. Read-Only"	CharacterString	Read	C	O
Object_Type	Binary_Value (5)	BACnetObjectType	Read	C	R
Present_Value	INACTIVE (0)	BACnetBinaryPV (Boolean)	Read	R	R
Out_Of_Service	FALSE (0)	BOOLEAN	Read	R	R
Status_Flags	All False (0,0,0,0)	BACnetStatusFlags	Read	R	R
Event_State	NORMAL (0)	BACnetEventState	Read	R	R
Reliability	NO_FAULT_DETECTED (0)	BACnetReliability	Read	R	O
Property_List	List of supported properties	Array of BACnetPropertyIdentifier	Read	R	R

* For O₂ sensor only, Object_Name is Gas_Alarm_Setpoint_Low_Low and is the most-urgent alarm setpoint

High Alarm Active

The High_Alarm_Active object's Present_Value property indicates whether the current gas concentration is within the high-alarm range.

Present Value

For all sensors, except O₂, this value is TRUE if the present sensor value is equal or higher than the High Alarm setpoint. For the O₂ sensor, this value is TRUE if the present sensor value is equal or lower than the Low-Low Alarm setpoint.

PresentValue will return to FALSE when the gas concentration is no longer within the alarm range.

This value is read-only and cannot be changed via BACnet. This is because it is continuously updated as a result of the sensor reading. Therefore, any change would immediately be overwritten.

Out of Service

OUT_OF_SERVICE is not implemented in this object. Reading OUT_OF_SERVICE will always return FALSE(0).

Reliability

The Reliability property is not used in this object. Reading Reliability will always return NO_FAULT_DETECTED,

Low Alarm Active					
Property	Default Value	Data Type	Access	Storage	Required
Object_Identifier	BV4 (Binary Value 4)	BACnetObjectIdentifier	Read	C	R
Object_Name	"Low Alarm Active"	CharacterString	Read	C	R
Description	"Gas is in the Low Alarm range. Read-Only"	CharacterString	Read	C	O
Object_Type	Binary_Value (5)	BACnetObjectType	Read	C	R
Present_Value	INACTIVE (0)	BACnetBinaryPV (Boolean)	Read	R	R
Out_Of_Service	FALSE (0)	BOOLEAN	Read	R	R
Status_Flags	All False (0,0,0,0)	BACnetStatusFlags	Read	R	R
Event_State	NORMAL (0)	BACnetEventState	Read	R	R
Reliability	NO_FAULT_DETECTED (0)	BACnetReliability	Read	R	O
Property_List	List of supported properties	Array of BACnetPropertyIdentifier	Read	R	R

Low Alarm Active

The Low_Alarm_Active object's Present_Value property indicates whether the current gas concentration is within the low-alarm range.

Present Value

For all sensors, except O₂, this value is TRUE if the present sensor value is equal or higher than the Low Alarm setpoint. For the O₂ sensor, this value is TRUE if the present sensor value is equal or lower than the Low Alarm setpoint.

PresentValue will return to FALSE when the gas concentration is no longer within the alarm range.

This value is read-only and cannot be changed via BACnet. This is because it is continuously updated as a result of the sensor reading. Therefore, any change would immediately be overwritten.

Out of Service

OUT_OF_SERVICE is not implemented in this object. Reading OUT_OF_SERVICE will always return FALSE(0).

Reliability

The Reliability property is not used in this object. Reading Reliability will always return NO_FAULT_DETECTED,

High Alarm Latch Mode Enabled					
Property	Default Value	Data Type	Access	Storage	Required
Object_Identifier	BV5 (Binary Value 5)	BACnetObjectIdentifier	Read	C	R
Object_Name	"High Alarm Latch Mode Enabled"*	CharacterString	Read	C	R
Description	"Set or Read Latch Enable for High Alarm"	CharacterString	Read	C	O
Object_Type	Binary_Value (5)	BACnetObjectType	Read	C	R
Present_Value	INACTIVE (0)	BACnetBinaryPV (Boolean)	Read / Write	R	R
Out_Of_Service	FALSE (0)	BOOLEAN	Read	R	R
Status_Flags	All False (0,0,0,0)	BACnetStatusFlags	Read	R	R
Event_State	NORMAL (0)	BACnetEventState	Read	R	R
Reliability	NO_FAULT_DETECTED (0)	BACnetReliability	Read	R	O
Property_List	List of supported properties	Array of BACnetPropertyIdentifier	Read	R	R

* For O₂ sensor only, Object_Name is Gas_Alarm_Setpoint_Low_Low and is the most-urgent alarm setpoint

High Alarm Latch Mode

Latch Mode allows an alarm condition to persist, even after the sensed values have returned to non-alarm levels.

Latch Mode can be enabled either on the physical device, using the LED display and magnetic switches, or via the BACnet interface.

Present Value

Enable Latch Mode for the High Alarm by writing a value of ACTIVE (1) to the Present_Value property. Disable Latch Mode by writing a value of INACTIVE (0) to the Present_Value property.

Out of Service

OUT_OF_SERVICE is not implemented in this object. Reading OUT_OF_SERVICE will always return FALSE(0).

Reliability

The Reliability property is not used in this object. Reading Reliability will always return NO_FAULT_DETECTED,

Low Latch Mode Enabled					
Property	Default Value	Data Type	Access	Storage	Required
Object_Identifier	BV6 (Binary Value 6)	BACnetObjectIdentifier	Read	C	R
Object_Name	“Low Alarm Latch Mode Enabled”	CharacterString	Read	C	R
Description	“Set or Read Latch Enable for Low Alarm”	CharacterString	Read	C	O
Object_Type	Binary_Value (5)	BACnetObjectType	Read	C	R
Present_Value	INACTIVE (0)	BACnetBinaryPV (Boolean)	Read / Write	R	R
Out_Of_Service	FALSE (0)	BOOLEAN	Read	R	R
Status_Flags	All False (0,0,0,0)	BACnetStatusFlags	Read	R	R
Event_State	NORMAL (0)	BACnetEventState	Read	R	R
Reliability	NO_FAULT_DETECTED (0)	BACnetReliability	Read	R	O
Property_List	List of supported properties	Array of BACnetPropertyIdentifier	Read	R	R

Low Latch Mode

Latch Mode allows an alarm condition to persist, even after the sensed values have returned to non-alarm levels.

Latch Mode can be enabled either on the physical device, using the LED display and magnetic switches, or via the BACnet interface.

Present Value

Enable Latch Mode for the Low Alarm by writing a value of ACTIVE (1) to the Present_Value property. Disable Latch Mode by writing a value of INACTIVE (0) to the Present_Value property.

Out of Service

OUT_OF_SERVICE is not implemented in this object. Reading OUT_OF_SERVICE will always return FALSE(0).

Reliability

The Reliability property is not used in this object. Reading Reliability will always return NO_FAULT_DETECTED,

High Alarm Latched					
Property	Default Value	Data Type	Access	Storage	Required
Object_Identifier	BV7 (Binary Value 7)	BACnetObjectIdentifier	Read	C	R
Object_Name	"High Alarm Latched" *	CharacterString	Read	C	R
Description	"Read Latched High Alarm or Clear Both"	CharacterString	Read	C	O
Object_Type	Binary_Value (5)	BACnetObjectType	Read	C	R
Present_Value	INACTIVE (0)	BACnetBinaryPV (Boolean)	Read / Write	R	R
Out_Of_Service	FALSE (0)	BOOLEAN	Read	R	R
Status_Flags	All False (0,0,0,0)	BACnetStatusFlags	Read	R	R
Event_State	NORMAL (0)	BACnetEventState	Read	R	R
Reliability	NO_FAULT_DETECTED (0)	BACnetReliability	Read	R	O
Property_List	List of supported properties	Array of BACnetPropertyIdentifier	Read	R	R

* For O₂ sensor only, Object_Name is "Low-Low Alarm Latched", and is the most-urgent alarm setpoint

High Alarm Latched

The Latched_Alarm object indicates whether an alarm has occurred and been latched, due to Latch Mode being Enabled.

The alarm condition can be reset (also known as "cleared" or "silenced") only if the Gas Concentration Value has returned to non-alarm levels.

A Latched Alarm can be reset either on the physical device, using the LED display and magnetic switches, or via the BACnet interface.

Present Value

To reset the Latched Alarms, write a value of INACTIVE (0) to the Present_Value property. Writing a value of ACTIVE (1) has no effect.

Clearing High Alarm Latched also clears Low Alarm Latched.

Out of Service

OUT_OF_SERVICE is not implemented in this object. Reading OUT_OF_SERVICE will always return FALSE(0).

Reliability

The Reliability property is not used in this object. Reading Reliability will always return NO_FAULT_DETECTED,

Low Alarm Latched					
Property	Default Value	Data Type	Access	Storage	Required
Object_Identifier	BV8 (Binary Value 8)	BACnetObjectIdentifier	Read	C	R
Object_Name	"Low Alarm Latched"	CharacterString	Read	C	R
Description	"Read Latched Low Alarm or Clear Both"	CharacterString	Read	C	O
Object_Type	Binary_Value (5)	BACnetObjectType	Read	C	R
Present_Value	INACTIVE (0)	BACnetBinaryPV (Boolean)	Read / Write	R	R
Out_Of_Service	FALSE (0)	BOOLEAN	Read	R	R
Status_Flags	All False (0,0,0,0)	BACnetStatusFlags	Read	R	R
Event_State	NORMAL (0)	BACnetEventState	Read	R	R
Reliability	NO_FAULT_DETECTED (0)	BACnetReliability	Read	R	O
Property_List	List of supported properties	Array of BACnetPropertyIdentifier	Read	R	R

Low Alarm Latched

The Latched_Alarm object indicates whether an alarm has occurred and been latched, due to Latch Mode being Enabled.

The alarm condition can be reset (also known as "cleared" or "silenced") only if the Gas Concentration Value has returned to non-alarm levels.

A Latched Alarm can be reset either on the physical device, using the LED display and magnetic switches, or via the BACnet interface.

Present Value

To reset the Latched Alarms, write a value of INACTIVE (0) to the Present_Value property. Writing a value of ACTIVE (1) has no effect.

Clearing Low Alarm Latched also clears High Alarm Latched.

Out of Service

OUT_OF_SERVICE is not implemented in this object. Reading OUT_OF_SERVICE will always return FALSE(0).

Reliability

The Reliability property is not used in this object. Reading Reliability will always return NO_FAULT_DETECTED,

21 Wiring Relays (Optional)

Wiring Relays 2-4

The optional relay board contains three (3) relays, designated as “Fail,” “Low” and “High.” The “Low” and “High” relays are factory set to be “Normally De-energized” and “Non-Latching” (user adjustable). The “Fail” relay is normally energized and is not user adjustable.

Detectors are shipped from the factory with pre-wired relays on the option board. These wires are used for testing the detector relays prior to shipment. Remove these wires before wiring the relay.

If your detector has an option board installed, wire the relays as described below. Wire Relays “Low” and “High” as follows

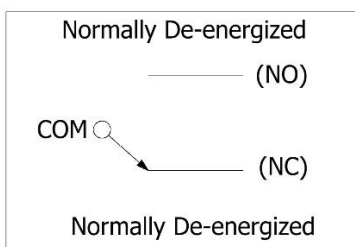

- 1) There are three terminals on each relay terminal block: NC, Com, & NO. Because the relay is normally de-energized wire the relays as in the diagram.
- 2) Wire the relays as outlined in the diagram.
- 3) When wiring has been completed, insert the board stack back inside the detector housing.
- 4) Replace /close the detector cover. For detectors with metallic conduit covers, tighten the hex head screw to secure the conduit cover.

22 Appendix- Troubleshooting Guide

Problem	Cause	Remedy
	No power to the detector.	Apply 12-30Vdc.
	Power input and 4-20mA output wires are reversed.	Verify positive voltage at the power input.
	Power supply voltage is less than 12Vdc.	Verify power supply voltage to be 12-30Vdc.
	There is no connection between the power supply and the current output of the detector.	Verify wiring.
	Sensor is incorrectly installed.	Verify wiring.
	Power supply voltage is greater than 30Vdc.	Verify power supply voltage to be 12-30Vdc.
	Sensor assembly is defective.	Disconnect sensor assembly. Measure the resistance between the colored wires. If resistance is between any pair of wires is <1ohm or >5ohms, replace sensor.
	Electronics board is defective.	Replace electronics board.
Unable to attain 4mA output current.	Current output of detector is shorted.	Verify wiring.
	4mA is misadjusted.	Adjust the 4mA level.
	Electronics board is defective.	Replace electronics board.
Unable to attain output current corresponding to %LEL concentration.	Actual concentration of calibration substance is not the expected concentration.	Verify the concentration of the calibration substance. Replace the calibration substance and/or assure proper delivery of the calibration substance to the sensor.
	Actual concentration of calibration substance is not the expected concentration.	Verify that the outside of the sensor assembly is clean. Blow away any debris on the sensor assy with "zero grade" air if necessary.
	4mA is misadjusted.	Adjust the 4mA level.
	Sensor assembly is defective.	Disconnect sensor assembly. Measure the resistance between the colored wires. If resistance is between any pair of wires is <1ohm or >5ohms, replace sensor.
	Electronics board is defective.	Replace electronics board.

23 Appendix- Combustible Selectivity Factors

Catalytic Bead Sensor Calibration and Spanning

Ideally, a combustible gas sensor should be calibrated with the target gas. In applications where methane will not be present, Sensidyne recommends the use of propane as a calibration gas or as span gas in conjunction with propane/target gas specific selectivity factors. It is recognized that many combustible gases are not readily available for calibration – in these instances it is an accepted industry practice to use a standard gas, typically methane or propane, in conjunction with selectivity factors (also known as k-factors) for setting a sensor's span. Catalytic bead combustible sensor characteristics govern the recommendations for when to use methane or propane for calibration or surrogate span purposes. Catalytic bead sensors can lose sensitivity due to various factors with sensor aging, overexposure, poisoning, or inhibition as typical factors. Due to methane gas combustion characteristics, catalytic bead sensors will lose sensitivity to methane prior to losing sensitivity for other gases. In applications where methane is the target gas or methane may be present with other gases, sensor calibration or surrogate spanning must be performed using methane gas with selectivity factors specific to methane and the target gas. In these applications, spanning with a gas other than methane can create unsafe conditions. In applications where methane will not be present, spanning with methane could result in loss of accuracy for the target gases as the sensor loses sensitivity to methane and retains (higher) sensitivity to the target gas.

Substance	Methane K-Factor	Propane K-Factor
Methane	1.00	0.56
Acetaldehyde	1.7	1.0
Acetic Acid	1.9	1.1
Acetic Anhydride	2.2	1.2
Acetone	1.9	1.1
Acetylene	1.8	1.0
Allyl Alcohol	2.0	1.1
Ammonia	0.8	0.4
n-Amyl Alcohol	3.0	1.7
Aniline	2.6	1.5
Benzene	2.4	1.3
Biphenyl	4.0	2.2
1,3-Butadiene	1.8	1.0
n-Butane	1.7	1.0
1-Butane	2.2	1.2
cis-2-Butane	2.1	1.2
trans-2-Butane	2.0	1.1
n-Butyl Alcohol	2.9	1.6
tert-Butyl Alcohol	1.4	0.8
n-Butyl Benzene	3.2	1.8
n-Butyric Acid	2.6	1.5
Carbon Monoxide	1.3	0.7
Cyanogen	1.1	0.6
Cyclohexane	2.4	1.3
Cyclopropane	1.6	0.9
n-Decane	3.0	1.7
Diethylamine	2.0	1.1

(table continues on next page)

Substance	Methane K-Factor	Propane K-Factor
Methane	1.00	0.56
Dimethylamine	1.7	1.0
2,3-Dimethyl	2.5	1.4
2,2-Dimethyl	2.5	1.4
1,4-Dioxane	2.2	1.2
Ethane	1.5	0.8
Ethyl Acetate	2	1.1
Ethyl Alcohol	1.4	0.8
Ethylamine	1.9	1.1
Ethylbenzene	2.8	1.6
Ethylcyclopentane	2.5	1.4
Ethylene	1.4	0.8
Ethylene Oxide	1.9	1.1
Ethyl Ether	2.2	1.2
Ethyl Formate	2.3	1.3
n-Heptane	2.6	1.5
n-Hexane	2.7	1.5
Hydrazine	2.2	1.2
Hydrogen	1.3	0.7
Hydrogen Cyanide	2.1	1.2
Isobutane	1.9	1.1
Isobutyl Alcohol	1.9	1.1
Isobutyl Benzene	3.1	1.7
Isopentane	2.2	1.2
Isopropyl Ether	2.3	1.3
Methyl Acetate	2	1.1
Methyl Alcohol	1.2	0.7

(table continues on next page)

Substance	Methane K-Factor	Propane K-Factor
Methane	1.00	0.56
Methylamine	1.3	0.7
Methylcyclohexane	2.3	1.3
Methyl Ether	1.6	0.9
Methyl Ethyl Ether	2.3	1.3
Methyl Ethyl Ketone	2.4	1.3
Methyl Formate	1.5	0.8
Methyl Propionate	2	1.1
Methyl Propyl	2.4	1.3
Napthalene	2.9	1.6
Nitromethane	13.7	7.7
-Nonane	3.2	1.8
n-Octane	2.7	1.5
n-Pentane	2.2	1.2
Propane	1.8	1.0
n-Propyl Alcohol	2.1	1.2
n-Propylamine	2.1	1.2
Propylene	1.9	1.1
Propylene Oxide	2.2	1.2
Propyne	2.4	1.3
Toluene	2.5	1.4
Triethylamine	2.5	1.4
Trimehtylamine	2.1	1.2
Vinyl Ethyl Ether	2.4	1.3
m-Xylene	2.6	1.5
o-Xylene	2.8	1.6
p-Xylene	2.6	1.5

24 Returned Material Authorization

DO NOT attempt to repair or modify instrument, except as specified in the Operation & Service Manual. If repair is needed, contact the Sensidyne Service Department to arrange for a Returned Material Authorization (RMA). Use ONLY genuine SENSIDYNE® replacement parts when performing any maintenance procedures described in this manual. Failure to do so may seriously impair instrument performance and affect Certification. Repair or alteration of the product beyond the scope of these maintenance instructions, or by anyone other than an authorized SENSIDYNE® service technician, could cause the product to fail to perform as designed and persons who rely on this product for their safety could sustain severe personal injury or death.

Sensidyne maintains an instrument service facility at the factory to provide its customers with both warranty and non-warranty repair. Sensidyne assumes no liability for service performed by personnel other than authorized Sensidyne authorized personnel. To facilitate the repair process, please contact the Sensidyne Service Department in advance for assistance with a problem which cannot be remedied and/or requires the return of the product to the factory. All returned products require a Returned Material Authorization (RMA) number. Sensidyne Service Department personnel may be reached at:

Sensidyne, LP
1000 112th Circle N, Suite 100
St. Petersburg, FL 33716 USA
800-451-9444 • +1 727-530-3602
+1 727-538-0671 [Service Fax] email: GasDetectionService@sensidyne.com

All non-warranty repair orders will have a minimum fee assessed whether the repair is authorized or not. This fee includes handling, administration and technical expenses for inspecting the instrument and providing an estimate. However, the estimate fee is waived if the repair is authorized.

If you wish to set a limit to the authorized repair cost, state a “not to exceed” figure on your purchase order. Please indicate if a price quotation is required before authorization of the repair cost, understanding that this invACKes extra cost and handling delay. Sensidyne’s repair policy is to perform all needed repairs to restore the instrument to its full operating condition.

Repairs are handled on a “first in - first out” basis. Your order may be expedited if you authorize an expediting fee. This will place your order next in line behind orders currently in process.

Pack the instrument and its accessories (preferably in their original packing) and enclose your return address, purchase order, shipping and billing information, RMA number, a description of the problem encountered with your instrument and any special instructions. All prices are subject to change without notice.

If this is the first time you are dealing directly with the factory, you will be asked to prepay or to authorize a COD shipment.

Send the instrument, prepaid, to:

SENSIDYNE
1000 112th Circle N, Suite 100
St. Petersburg, FL 33716 USA
ATTENTION: Service Department
RMA #: _____

SERVICE OPTIONS

The Sensidyne Service Department offers a variety of service options which will minimize costly interruptions and maintenance costs. These options include initial training, on-site technical assistance, and full factory repairs. Sensidyne has developed several programs which offer options best suited to your applications and needs. For further information, contact the Sensidyne Service Department at the following numbers: 800-451-9444 • +1 727-530-3602 • +1 727-538-0671 [Service Fax].

Manufactured by:

Sensidyne, LP

1000 112th Circle N, Suite 100

St. Petersburg, Florida 33716

USA

800-451-9444 • +1 727-530-3602 • 727-539-0550 [fax]

+1 727-538-0671 (Service Fax)

www.Sensidyne.com • info@sensidyne.com • GasDetectionService@sensidyne.com

Authorized EU Representative

Schauenburg Electronic Technologies GmbH

Weseler Str. 35 · 45478

Mülheim-Ruhr Germany

+49 (0) 208 9 99 10 • +49 (0) 208 5 41 10 [fax]

www.schauenburg.com • international@schauenburg.com

SENSIDYNE[®]

Sensidyne, LP • 1000 112th Circle N, Suite 100

St. Petersburg, Florida 33716 USA

800-451-9444 • +1 727-530-3602 • +1 727-539-0550 [fax]

web: www.sensidyne.com • e-mail: info@sensidyne.com